



Features & Options

- Included Barometric pressure sensor and optional light level sensor
- User adjustable settings to maximize battery life while ensuring the BMS gets the info it needs
- Transmits to a receiver and output modules with multiple integration methods into the BMS

BAPI's Outside Air Wireless Sensor measures environmental values and transmits the data via Bluetooth Low Energy to a receiver and output modules with multiple integration methods into the BMS. This unit features a rugged IP66-rated BAPI-Box enclosure with a UV-resistant plastic shield. It is available with optional light level sensing.



Specifications

Battery Power: Two included 3.6V 14505, 14500 or equivalent lithium batteries (Standard AA batteries are not compatible)

Wire Power: 9 to 30 VDC or 24 VAC, halfwave rectified

Sensor Accuracy:

Temp: $\pm 1.0^{\circ}\text{F}$ (0.55°C) from 32 to 158°F (0 to 70°C)
 Humidity: $\pm 2\%\text{RH}$ @ 77°F (25°C), 20 to 80%RH
 Barometric Pressure: ± 2 mbar @ 25°C (0.40"H₂O)
 Light Level: 10 Lux + 10% of reading.

Temperature Range: -4 to 221°F (-20 to 105°C)

Light Level Sensing Range: 0 to 64,000 lux

Transmission Distance: Varies by application*

Environmental Operation Range:

Temp: -4 to 149°F (-20 to 65°C)
 Humidity: 10 to 90%RH, non-condensing

Enclosure Rating, Material & Material Rating:

IP66, UV-Resistant Polycarbonate, UL94 V-0

Frequency: 2.4 GHz (Bluetooth Low Energy)

Receiver Sensitivity: -97 dBm

User Adjustable Settings:

Delta T (Temp): 0.1°F/C to 5.0°F/C | Delta T (Humidity): 0.1%RH to 5.0%RH
 Transmit Interval: 1 min to 30 min | Sample Interval: 30 sec to 5 min

Agency: RoHS | Contains FCC ID: QOQGM210P | IC: 5123A-GM210P

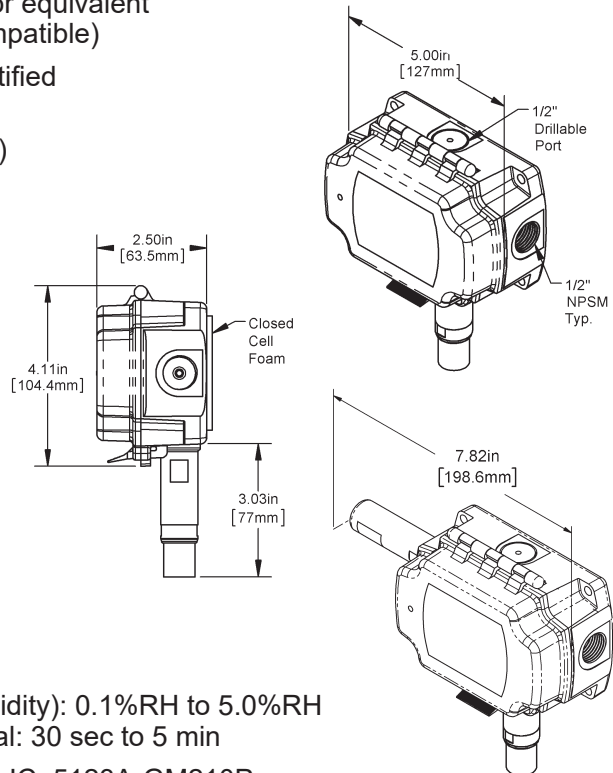

*In-building range is dependent on obstructions such as furniture and walls and the density of those materials. In wide open spaces, the distance may be greater; in dense spaces, the distance may be less.

**Actual battery life is dependent on the sensor's adjustable settings and environmental conditions.

BAPI-Box Units Calculated Battery Life**		
Transmit Interval	Sample Rate	Estimated Life (years)
30 sec	30 sec	1.04
1 min	1 min	1.95
3 min	1 min	3.46
5 min	5 min	4.63
10 min	5 min	7.02





Ordering Information

BATTERY POWER UNITS

BA/WTH-BLE-O-BB-BAT

Wireless Outside Air Temp/Humidity and Barometric Pressure Sensor, Battery Power

BA/WTH-BLE-LL-O-BB-BAT

Wireless Outside Air Temp/Humidity, Light Level & Barometric Pressure Sensor, Battery Power

BALI14505: 3.6V Lithium Battery

WIRE POWER UNITS

BA/WTH-BLE-O-BB-PWR

Wireless Outside Air Temp/Humidity and Barometric Pressure Sensor, Wire Power

BA/WTH-BLE-LL-O-BB-PWR

Wireless Outside Air Temp/Humidity, Light Level & Barometric Pressure Sensor, Wire Power



Associated Receiver and Output Modules

RECEIVER - Collects the data from up to 28 wireless sensors and transfers the data to the Analog or Digital Output Modules for integration into the BAS.

DIGITAL AND ANALOG OUTPUT MODULES - The BACnet IP Module converts the data from up to 28 sensors for integration into the management level BACnet IP network. The BACnet MS/TP or Modbus RTU Module converts the data from up to 28 sensors for integration into the field level BACnet or Modbus Network. The Analog Output Modules convert the sensor data to a voltage or resistance for the controller analog inputs.

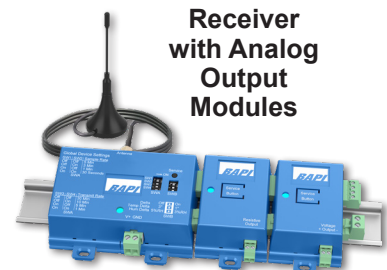

Receiver
with Analog
Output
Modules

Wireless Site Verification App

BAPI recommends that all wireless customers conduct a site verification and send the information to BAPI prior to installing the system to ensure optimum performance. Our experts will review the data and follow up with an approval or recommendations if needed. A site verification app is available on the BAPI website at:

<https://www.bapivac.com/wireless-site-verification/>

