



Features & Options

- Rugged IP66/NEMA 4 enclosure with probe lengths from 4" to 18" (102 to 457mm)
- User adjustable settings to maximize battery life while ensuring the BMS gets the info it needs
- Transmits to a receiver and output modules with multiple integration methods into the BMS

BAPI's Duct Wireless Sensor measures the temperature and transmits the data via Bluetooth Low Energy to a receiver and output modules with multiple integration methods into the BMS.

This unit features a rugged IP66-rated BAPI-Box enclosure and 1/4" (6.4mm) stainless steel probe with probe lengths from 4" to 18" (102 to 457mm).



Wireless Duct Temperature Sensor



Specifications

Battery Power:

Two included 3.6V 14505, 14500 or equivalent lithium batteries (Standard AA batteries are not compatible)

Wire Power: 9 to 30 VDC or 24 VAC, halfwave rectified

Temperature Sensor Accuracy:

±1.0°F (0.55°C) from 32 to 158°F (0 to 70°C)

Temperature Range: -4 to 221°F (-20 to 105°C)

Transmission Distance: Varies by application*

Environmental Operation Range:

Temp: -4 to 149°F (-20 to 65°C)

Humidity: 10 to 90%RH, non-condensing

Enclosure Rating, Material & Material Rating:

IP66, UV-Resistant Polycarbonate, UL94 V-0

Frequency: 2.4 GHz (Bluetooth Low Energy)

Receiver Sensitivity: -97 dBm

User Adjustable Settings:

Delta T (Temp): 0.1°F/C to 5.0°F/C

Transmit Interval: 1 min to 30 min

Sample Interval: 30 sec to 5 min

Agency: RoHS | Contains FCC ID: QOQGM210P | IC: 5123A-GM210P

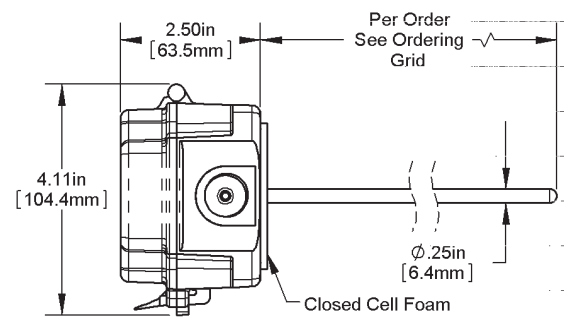
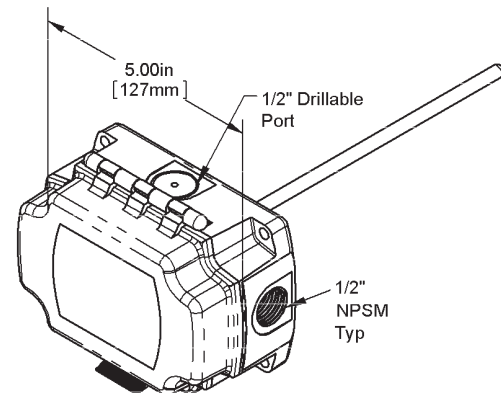

*In-building range is dependent on obstructions such as furniture and walls and the density of those materials. In wide open spaces, the distance may be greater; in dense spaces, the distance may be less.

**Actual battery life is dependent on the sensor's adjustable settings and environmental conditions.

BAPI-Box Units Calculated Battery Life**		
Transmit Interval	Sample Rate	Estimated Life (years)
30 sec	30 sec	1.04
1 min	1 min	1.95
3 min	1 min	3.46
5 min	5 min	4.63
10 min	5 min	7.02





Ordering Information

BATTERY POWER UNITS

BA/WT-BLE-D-4-BB-BAT

Wireless Duct Temp Sensor, 4" (102mm) Probe Length, Battery Power

BA/WT-BLE-D-8-BB-BAT

Wireless Duct Temp Sensor, 8" (203mm) Probe Length, Battery Power

BA/WT-BLE-D-12-BB-BAT

Wireless Duct Temp Sensor, 12" (305mm) Probe Length, Battery Power

BA/WT-BLE-D-18-BB-BAT

Wireless Duct Temp Sensor, 18" (457mm) Probe Length, Battery Power

BA/LI14505: 3.6V Lithium Battery

WIRE POWER UNITS

BA/WT-BLE-D-4-BB-PWR

Wireless Duct Temp Sensor, 4" (102mm) Probe Length, Wire Power

BA/WT-BLE-D-8-BB-PWR

Wireless Duct Temp Sensor, 8" (203mm) Probe Length, Wire Power

BA/WT-BLE-D-12-BB-PWR

Wireless Duct Temp Sensor, 12" (305mm) Probe Length, Wire Power

BA/WT-BLE-D-18-BB-PWR

Wireless Duct Temp Sensor, 18" (457mm) Probe Length, Wire Power

Custom probe lengths available.



Associated Receiver and Output Modules

RECEIVER - Collects the data from up to 28 wireless sensors and transfers the data to the Analog or Digital Output Modules for integration into the BAS.

DIGITAL AND ANALOG OUTPUT MODULES - The BACnet IP Module converts the data from up to 28 sensors for integration into the management level BACnet IP network. The BACnet MS/TP or Modbus RTU Module converts the data from up to 28 sensors for integration into the field level BACnet or Modbus Network. The Analog Output Modules convert the sensor data to a voltage or resistance for the controller analog inputs.



Receiver with Analog Output Modules

Wireless Site Verification App

BAPI recommends that all wireless customers conduct a site verification and send the information to BAPI prior to installing the system to ensure optimum performance. Our experts will review the data and follow up with an approval or recommendations if needed. A site verification app is available on the BAPI website at:

<https://www.bapihvac.com/wireless-site-verification/>

