



## Features & Options

- Rugged IP66/NEMA 4 enclosure
- User adjustable settings to maximize battery life while ensuring the BMS gets the info it needs
- Transmits to a receiver and output modules with multiple integration methods into the BMS

BAPI's Duct Wireless Sensor measures the temperature and humidity and transmits the data via Bluetooth Low Energy to a receiver and output modules with multiple integration methods into the BMS.

This unit features a rugged IP66-rated BAPI-Box enclosure and replaceable stainless steel filter.



Wireless Duct Temperature and Humidity Sensor



## Specifications

### Battery Power:

Two included 3.6V 14505, 14500 or equivalent lithium batteries (Standard AA batteries are not compatible)

### Wire Power:

9 to 30 VDC or 24 VAC, halfwave rectified

### Sensor Accuracy:

Temp:  $\pm 1.0^{\circ}\text{F}$  ( $0.55^{\circ}\text{C}$ ) from 32 to 158 $^{\circ}\text{F}$  (0 to 70 $^{\circ}\text{C}$ )  
Humidity:  $\pm 2\%\text{RH}$  @ 77 $^{\circ}\text{F}$  (25 $^{\circ}\text{C}$ ), 20 to 80%RH

**Temperature Range:** -4 to 221 $^{\circ}\text{F}$  (-20 to 105 $^{\circ}\text{C}$ )

**Transmission Distance:** Varies by application\*

### Environmental Operation Range:

Temp: -4 to 149 $^{\circ}\text{F}$  (-20 to 65 $^{\circ}\text{C}$ )  
Humidity: 10 to 90%RH, non-condensing

### Enclosure Rating, Material & Material Rating:

IP66, UV-Resistant Polycarbonate, UL94 V-0

**Frequency:** 2.4 GHz (Bluetooth Low Energy)

**Receiver Sensitivity:** -97 dBm

### User Adjustable Settings:

Delta T (Temp): 0.1 $^{\circ}\text{F}/\text{C}$  to 5.0 $^{\circ}\text{F}/\text{C}$   
Delta T (Humidity): 0.1%RH to 5.0%RH  
Transmit Interval: 1 min to 30 min  
Sample Interval: 30 sec to 5 min

**Agency:** RoHS | Contains FCC ID: QOQGM210P |  
IC: 5123A-GM210P

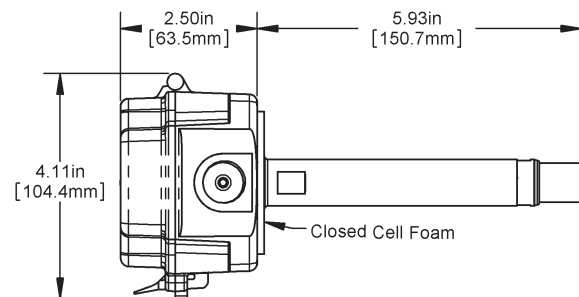
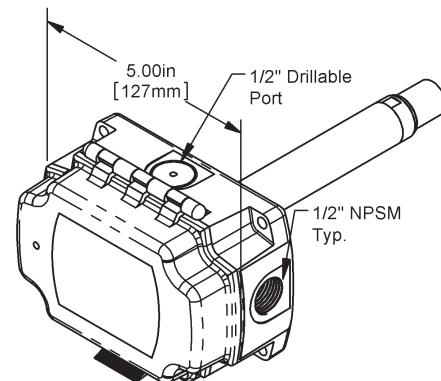

BAPI-Box Units Calculated Battery Life**		
Transmit Interval	Sample Rate	Estimated Life (years)
30 sec	30 sec	1.04
1 min	1 min	1.95
3 min	1 min	3.46
5 min	5 min	4.63
10 min	5 min	7.02

\*In-building range is dependent on obstructions such as furniture and walls and the density of those materials. In wide open spaces, the distance may be greater; in dense spaces, the distance may be less.

\*\*Actual battery life is dependent on the sensor's adjustable settings and environmental conditions.





# Duct Temp/Humidity Sensor

F9

Wireless System

Submittal sheets without List Prices are available on our website at [www.bapihvac.com](http://www.bapihvac.com)

## Ordering Information

### BATTERY POWER UNIT

List Price

#### BA/WTH-BLE-D-BB-BAT

Wireless Duct Temperature & Humidity Sensor, Battery Power .....\$406

#### BA/LI14505

3.6V Lithium Battery.....\$3 (net price)

### WIRE POWER UNIT

#### BA/WTH-BLE-D-BB-PWR

Wireless Duct Temperature & Humidity Sensor, Wire Power .....\$406



## Associated Receiver and Output Modules

**RECEIVER** - Collects the data from up to 28 wireless sensors and transfers the data to the Analog or Digital Output Modules for integration into the BAS.

**DIGITAL AND ANALOG OUTPUT MODULES** - The BACnet IP Module converts the data from up to 28 sensors for integration into the management level BACnet IP network. The BACnet MS/TP or Modbus RTU Module converts the data from up to 28 sensors for integration into the field level BACnet or Modbus Network. The Analog Output Modules convert the sensor data to a voltage or resistance for the controller analog inputs.



Receiver with Analog Output Modules

## Wireless Site Verification App

BAPI recommends that all wireless customers conduct a site verification and send the information to BAPI prior to installing the system to ensure optimum performance. Our experts will review the data and follow up with an approval or recommendations if needed. A site verification app is available on the BAPI website at:

<https://www.bapihvac.com/wireless-site-verification/>

