

Product Identification and Overview

- Several options for Temperature, Humidity, Carbon Monoxide (CO) and Nitrogen Dioxide (NO₂)
- Field configurable BACnet MS/TP and MODBUS RTU output
- CO measurement range of 0 to 500 ppm
- NO₂ measurement range of 0 to 20 ppm
- CO and NO₂ sensing elements last approximately 7 years and are automatically self-tested daily
- Electronic copies of CO and NO₂ certificates of calibration available upon request at no extra charge
- Rough service wall/beam mount or duct mount – perfect for parking structures, equipment rooms or warehouses.

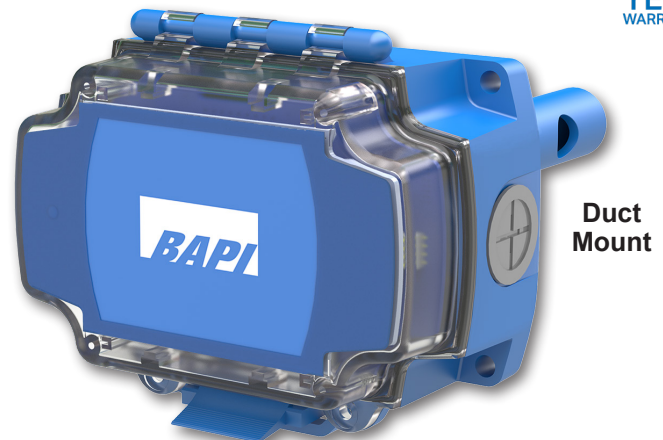
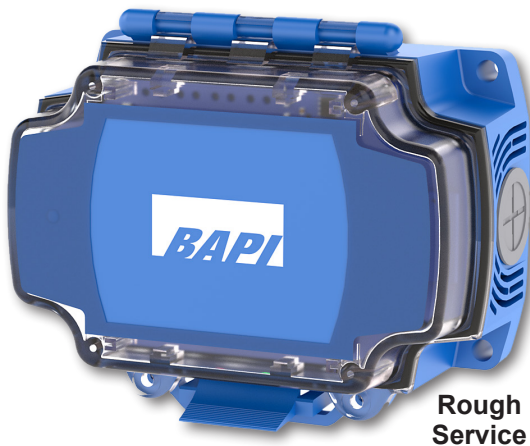

Note:

CO and/or NO₂ sensors must be installed and powered within 4 months of purchase to prevent loss of accuracy.

Configuring

These steps are often easier to do before mounting the sensor and can be completed without connecting power to the sensor. If the sensor is powered while changes are made, power must be cycled for the changes to take effect.

Sensor Address

Each sensor on the RS-485 Line must be assigned a unique address. DIP switches 1 through 8 set the binary address for the sensor. An address of 0 is invalid. (Fig 4)

BACnet and MODBUS Configuration

1. Use BAPI's Device Configuration utility and a computer's USB connection to complete all other configuration changes. The sensor has a USB-C connection.
2. Download the utility from the Digital CO and NO₂ Sensor webpage on BAPI's website (link below) and follow the instructions for its user guide.
(Digital CO and NO₂ Sensor webpage: <https://www.bapihvac.com/product/digital-co-and-no2-sensor/>)
3. MODBUS uses Little-endian for byte order.

Wall Mounting

- 1 BAPI recommends using Clean-Cut Tool (part number BA/CLN-CUT-50) to open your wire-entry port to avoid damaging the circuit board.
2. Mount the unit on a solid, non-vibrating surface 3 to 5 feet (900 to 1500mm) above floor level or as specified by local building codes. Do not mount near supply or return diffusers.
3. Mount in a horizontal orientation with the enclosure hinge at the top as shown in Fig 1. Mounting in other orientations increases the likelihood that water droplets will touch the sensor elements and damage the sensor.
4. Use the mounting template on the next page (or the enclosure itself) to mark the pilot-hole locations. Use the 4 included #10 (M5) screws on the four mounting feet of the enclosure. A pilot-hole makes mounting easier.
5. Snug up the screws so that the foam backing is partially depressed but do not over-tighten or strip the screw threads. The foam is for insulation and vibration dampening.
6. Place the provided #6 screws into the holes on each side of the lid latch to make the cover tamper resistant.

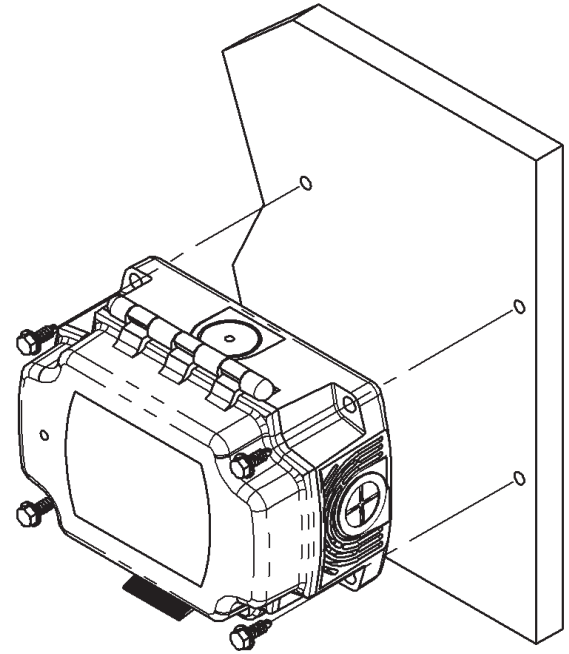

Fig. 1: Rough service unit wall mounting

Duct Unit Mounting

- 1 BAPI recommends using Clean-Cut Tool (part number BA/CLN-CUT-50) to open your wire-entry port to avoid damaging the circuit board.
2. BAPI recommends placing the sensor in the middle of the duct wall, away from stratified air, to achieve the best reading. The unit should also be a minimum of 3 duct diameters or widths from an elbow, damper or other duct restriction.
3. Drill a 1" (25mm) hole for the aspiration probe. Position the box so that airflow is directly into the holes on one side of the aspiration probe. There are no upstream or downstream holes, the air direction is not important.
4. Mount the enclosure to the duct using BAPI recommended #10 screws (provided) through a minimum of two of the mounting feet on opposite corners. A 1/8" pilot screw hole in the duct makes mounting easier. Use the enclosure mounting feet to mark the pilot-hole locations.
5. Snug up the screws so that the foam backing is depressed to prevent air leakage but do not over-tighten or strip the threads.
6. Use the provided #6 screws to secure the cover for IP66 rating.

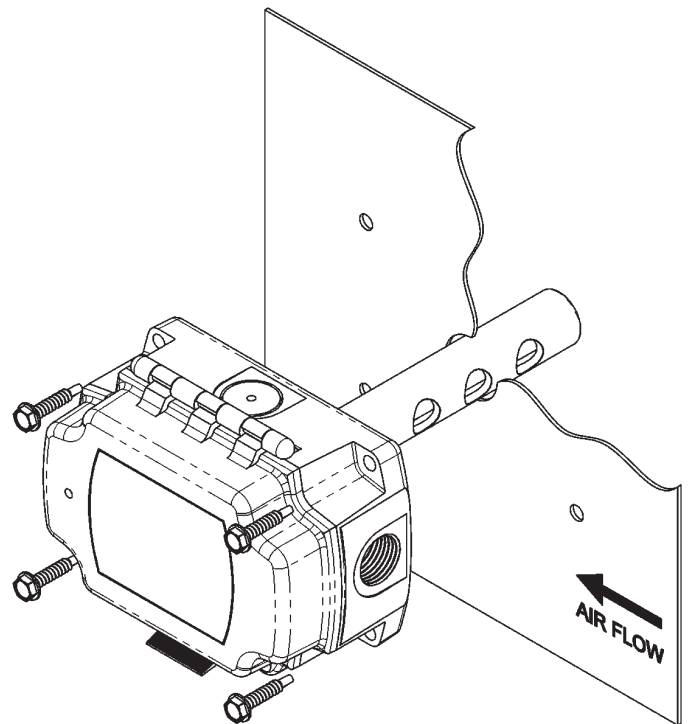
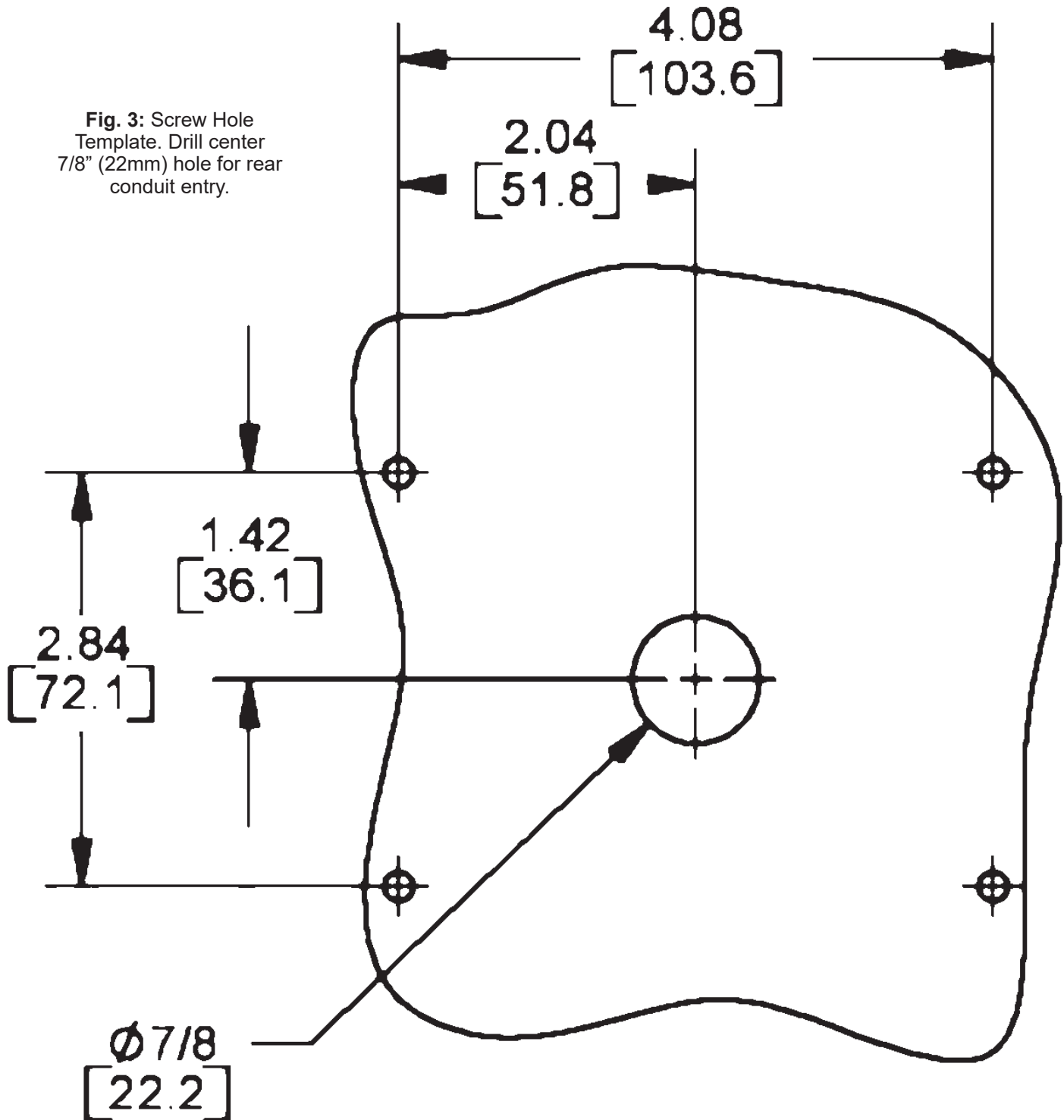

Fig. 2: Duct unit mounting

Mounting Template (Shown actual size)

Fig. 3: Screw Hole Template. Drill center 7/8" (22mm) hole for rear conduit entry.



Termination

BAPI recommends using twisted pair of at least 22AWG. Larger gauge wire may be required for long runs. All wiring must comply with the National Electric Code (NEC) and local codes.

Do NOT run this device's wiring in the same conduit as AC power wiring of NEC class 1, NEC class 2, NEC class 3 or with wiring used to supply highly inductive loads such as motors, contactors and relays. BAPI's tests show that fluctuating and inaccurate signal levels are possible when AC power wiring is present in the same conduit as the signal lines. If you are experiencing any of these difficulties, please contact your BAPI representative.



BAPI recommends wiring the product with power disconnected. Proper supply voltage, polarity and wiring connections are important to a successful installation. Not observing these recommendations may damage the product and void the warranty.

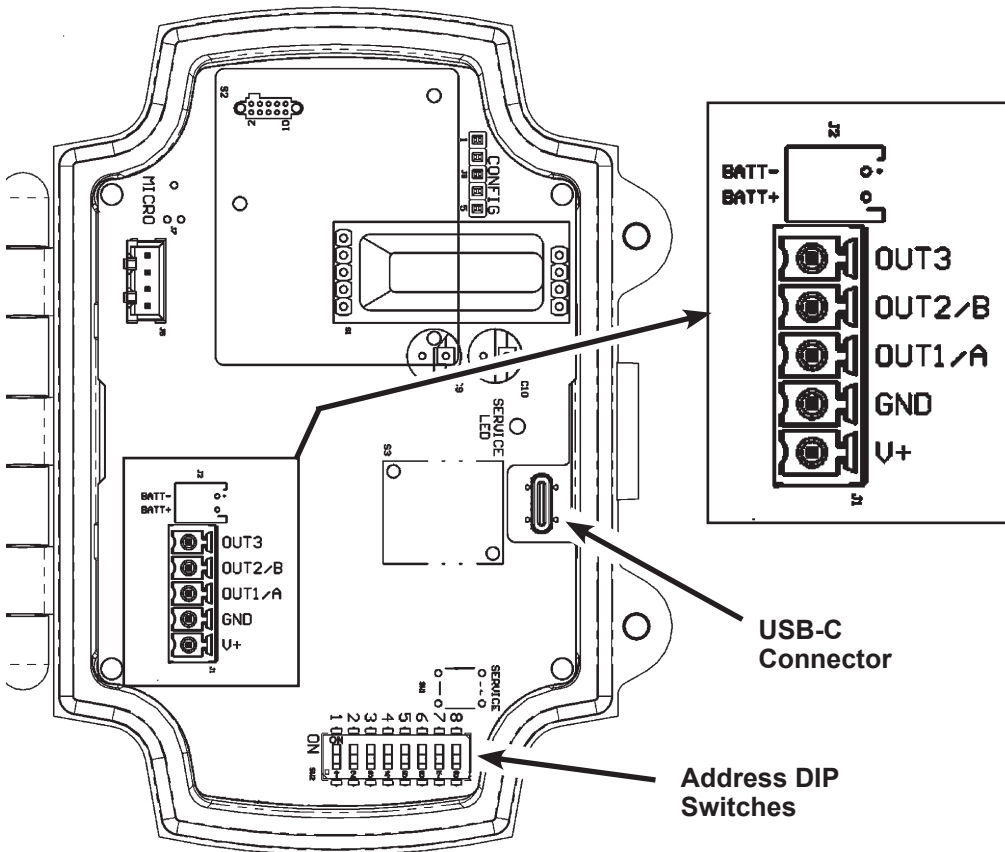

WIRE TERMINATIONS

OUT3

Not used

OUT2/B

BACnet/Modbus RS485

OUT1/A

BACnet/Modbus RS485

GND

Power Ground

V+

15 to 40VDC, 35mA max

18 to 24VAC, 2.7VA max

Fig. 4:
Field Wiring
Terminals

Connecting Multiple Sensors on the Same RS485 Line

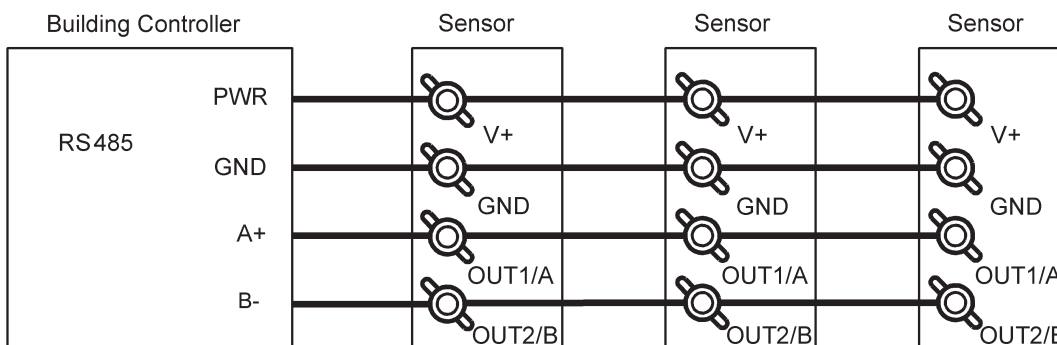

BAPI recommends a maximum of 64 sensors with BACnet and 32 sensors with MODBUS to reduce network congestion. Maximum wire length of 4,000 ft (1,200 m).

Fig. 5: Multiple sensors connected to the same RS485 Line

Keeping the Enclosure Air Tight After Termination

For the sensor to work correctly, the wiring entrance must remain air tight. If the sensor is mounted to a hollow wall and wired through its back, or wired with conduit, it is possible that a draft of clean air may fill the enclosure through the wiring opening. This draft may prevent the unit from measuring ambient gas. BAPI recommends either a liquid-tight fitting or plugging the conduit at the enclosure.

- **Liquid-Tight Fitting** – BAPI’s Liquid-Tight Fitting (BA/LTF) allows wire cables of 0.1 to 0.3 inch (2.5 to 7.6mm) to outside diameter to enter the box. Tightening the collar onto the wire cable keeps the wiring entrance air tight.
- **Conduit** – Included with the sensor is a foam plug to seal the ½ inch (13mm) EMT. Place the wires into the plug as shown in Fig. 5 and then insert the plug into the conduit sealing the conduit.

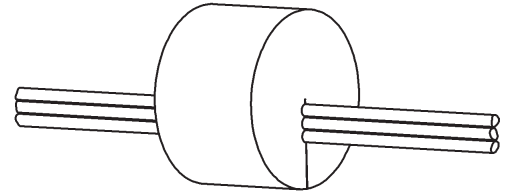

Fig. 6:
Wires Through Foam Plug

Operation

INITIAL POWER UP

1. The sensor will immediately begin sending readings upon powerup. However, allow 3 hrs for the CO and NO₂ sensing elements to warmup before their readings can be considered accurate.

NORMAL OPERATION

1. The unit will automatically perform a self-test every 24 hours to assure that the CO and NO₂ sensing elements are not at end of life.
2. The self-test typically takes 1 minute to run, but may take up to 15 minutes. During the self-test, the sensor reports its last CO and/or NO₂ reading prior to the start of self-test.
 - a. A failed self-test for BACnet is indicated by the Reliability property of the object showing “Communication Failure.”
 - b. A failed self-test for MODBUS is indicated by the deadCount register of the object showing 10 or greater.

MODBUS Map

Sensor Table					
Sensor	Input Type	Range (min)	Range (max)	Unit Type	Units of Measure
CO	5	0	500	96	PPM
NO2	7	0	20	96	PPM
Temperature (°F)	9	-40	158	64	°F
Temperature (°C)	10	-40	70	62	°C
Relative Humidity	11	0	100	29	%



Digital CO and NO₂ Sensors

Installation & Operating Instructions

53000_ins_Digital_CO_NO2_BB

rev. 07/24/25

MODBUS Map continued...

The sensors in the Sensor Table are listed in priority order. The registers that are used are dependant on the priority order and which are present.

For example:

- A sensor that includes only CO and NO₂ will assign CO to the Sensor 1 registers and NO₂ to the Sensor 2 registers.
- A sensor that includes only NO₂, Temperature, and Humidity will assign NO₂ to the Sensor 1 registers, Temperature (°F) to the Sensor 2 registers, Temperature (°C) to the Sensor 3 registers, and Humidity to the Sensor 4 registers.

Function 3 Registers					
Name	Location	Data Type	Read/Write	Value	Notes
Firmware Version	0x4000	uint16[8]	R	xx123456	
Sensor Serial Number	0x4008	uint16[10]	R	BAPxxxxxxx	
Baud Rate	0x406C	uint32	R/W	9600	Use BAPI Device Configuration utility to edit.
Stop Bits	0x406F	uint16	R/W	0	Use BAPI Device Configuration utility to edit.
Parity	0x4070	uint16	R/W	0	Use BAPI Device Configuration utility to edit.
Sensor 1 Input Type	0x408C	uint16	R	see Sensor Table	Number code for the type of sensor.
Sensor 1 Range (min)	0x408E	float32	R	see Sensor Table	The min sensor value for normal operation.
Sensor 1 Range (max)	0x4090	float32	R	see Sensor Table	The max sensor value for normal operation.
Sensor 1 Unit Type	0x4092	uint16	R	see Sensor Table	The BACnet unit type. See https://store.chipkin.com/articles/bacnet-engineering-units-enumerations
Sensor 1 Poll Interval	0x4096	uint16	R	1000	The polling rate of the sensor in milliseconds.
Sensor 2 Input Type	0x40BA	uint16	R	see Sensor Table	
Sensor 2 Range (min)	0x40BC	float32	R	see Sensor Table	
Sensor 2 Range (max)	0x40BE	float32	R	see Sensor Table	
Sensor 2 Unit Type	0x40C0	uint16	R	see Sensor Table	
Sensor 2 Poll Interval	0x40C4	uint16	R	1000	
Sensor 3 Input Type	0x40E8	uint16	R	see Sensor Table	
Sensor 3 Range (min)	0x40EA	float32	R	see Sensor Table	
Sensor 3 Range (max)	0x40EC	float32	R	see Sensor Table	
Sensor 3 Unit Type	0x40EE	uint16	R	see Sensor Table	
Sensor 3 Poll Interval	0x40F2	uint16	R	1000	
Sensor 4 Input Type	0x4116	uint16	R	see Sensor Table	
Sensor 4 Range (min)	0x4118	float32	R	see Sensor Table	
Sensor 4 Range (max)	0x411A	float32	R	see Sensor Table	
Sensor 4 Unit Type	0x411C	uint16	R	see Sensor Table	
Sensor 4 Poll Interval	0x4120	uint16	R	1000	
Sensor 5 Input Type	0x4144	uint16	R	see Sensor Table	
Sensor 5 Range (min)	0x4146	float32	R	see Sensor Table	
Sensor 5 Range (max)	0x4148	float32	R	see Sensor Table	
Sensor 5 Unit Type	0x414A	uint16	R	see Sensor Table	
Sensor 5 Poll Interval	0x414E	uint16	R	1000	

Function 4 Registers			
Name	Location	Data Type	Notes
Sensor 1 Output Value	0x3002	float32	The sensing element value.
Sensor 1 Dead Count	0x3004	uint16	The deadCount of the sensor. Will increment each time a communication failure happens and resets to 0 upon each successful sensor reading.
Sensor 2 Output Value	0x3008	float32	
Sensor 2 Dead Count	0x300A	uint16	
Sensor 3 Output Value	0x300E	float32	
Sensor 3 Dead Count	0x3010	uint16	
Sensor 4 Output Value	0x3014	float32	
Sensor 4 Dead Count	0x3016	uint16	
Sensor 5 Output Value	0x301A	float32	
Sensor 5 Dead Count	0x301C	uint16	



Maintenance

The unit should be vacuumed clean once a year or more, depending on the rate of accumulation of any dust or dirt. To avoid sensor damage, the unit **MUST NOT** be submerged in any liquids. Hosing or splashing of the unit with any liquids must also be avoided and may void the warranty.

Diagnostics

POSSIBLE PROBLEMS: POSSIBLE SOLUTIONS:

- | | |
|-------------------------|--|
| General troubleshooting | <ul style="list-style-type: none">- Determine that the input is set up correctly in the controller's and building automation software.- Check wiring for proper termination- Check for corrosion at either the controller or the sensor. Clean off the corrosion, re-strip the interconnecting wire and reapply the connection. In extreme cases, replace the controller, interconnecting wire and/or sensor.- Check that the wiring is good between the sensor and the controller. To do this, label the wires at both ends and then disconnect the wires from the controller and the sensor. With the interconnecting wires separated at both ends, use a multimeter to measure the resistance from wire-to-wire. The meter should read either greater than 10 Meg-ohms, open or OL depending on the style of meter. Now connect the wires together at one end and measure the resistance from wire-to-wire with a multimeter at the other end. The meter should read less than 10 ohms for 22 gauge or larger wire and runs of 250 feet (76m) or less. The resistance may be slightly higher for smaller wires or longer runs. If either test fails, replace the wire. |
| Unit does not operate | <ul style="list-style-type: none">- Cycle power.- Disconnect the power wires from the power source and check for proper power at the source. If the voltage is outside the specifications, troubleshoot the power source. Reconnect power wires to the source when finished- Disconnect the power wires at the sensor and verify that the power is the same at the sensor as at the power source. If the voltage is different at the sensor from the source, troubleshoot the wiring. Reconnect power wires to sensor when finished.- Measure the power at the sensor with the power wires connected to the power source and to the sensor. If the voltage is outside the limits, but within the limits when the wires are disconnected to the sensor, call your BAPI representative. |
| Communication issues | <ul style="list-style-type: none">- Typical RS485 troubleshooting steps include the following:<ul style="list-style-type: none">• Confirm polarity OUT1/A and OUT2/B. Try swapping wires if not sure of the polarity.• Confirm all devices share a common RS485 reference (ground).• Confirm settings such as baud rate, parity, etc. match on all devices connected to the network.• Confirm that the sensor's DIP switch address is unique on the network, i.e. no other devices use the same address.• For BACnet settings, confirm that the max master setting on all devices is higher or equal to the highest address on the network.• For BACnet settings, confirm that the device object name and device object number are unique on the network, i.e. no other devices use the same values. |

Specifications

Power: 15 to 40VDC, 35mA max | 18 to 24VAC, 2.7VA max

Field Wiring Terminal Blocks: 18 to 24 AWG

Environmental Operation Range:

-4 to 104°F (-20 to 40°C) | 15 to 95%RH Non-condensing

Enclosure Material: UV-resistant Polycarbonate, UL94 V-0

CO and NO₂ Sensor Element Life: 7 years typical

Agency: RoHS

CO Sensor:

Type: Electrochemical

Range: 0 to 500 ppm

Accuracy: ±6 ppm from 0 to 200 ppm | ±25 ppm from 200 to 500 ppm

NO₂ Sensor:

Type: Electrochemical

Range: 0 to 20 ppm

Accuracy: ±0.5 ppm from 0 to 10 ppm

Temperature Sensor:

Range: -40 to 158°F (-40 to 70°C)

Accuracy: ±0.54°F (±0.3°C) from 68 to 104°F (20 to 40°C) [see graph]

Humidity Sensor:

Range: 0 to 100%RH

Accuracy: ±2%RH from 20 to 80% @ 25°C

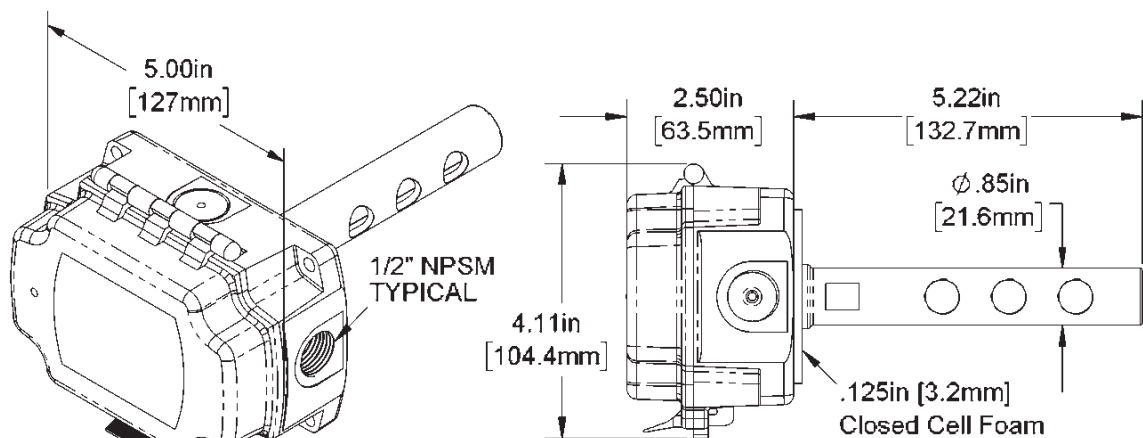
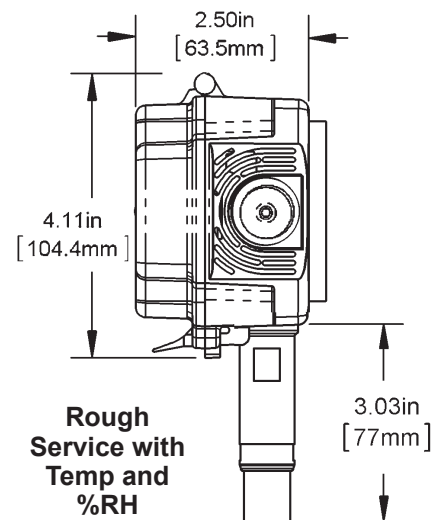
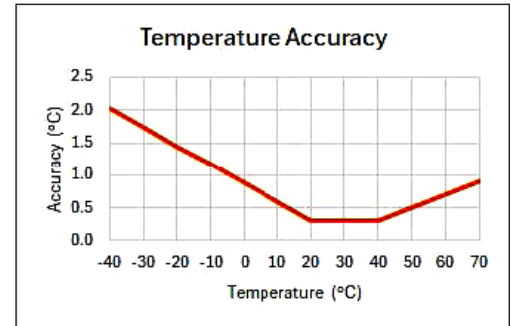

Duct Mount

(Dimensions are the same for the rough service unit without the aspiration tube)