

Overview and Identification

- Included Barometric pressure sensor and optional light level sensor
- User adjustable settings via receiver or WAM
- Onboard memory to store readings
- Transmits to a digital gateway or a wireless-to-analog receiver

BAPI's Outside Air Wireless Sensor measures environmental values and transmits the data via Bluetooth Low Energy to a receiver or gateway.

This unit features a rugged IP66-rated BAPI-Box enclosure with a UV-resistant plastic shield. It is available with optional light level sensing.

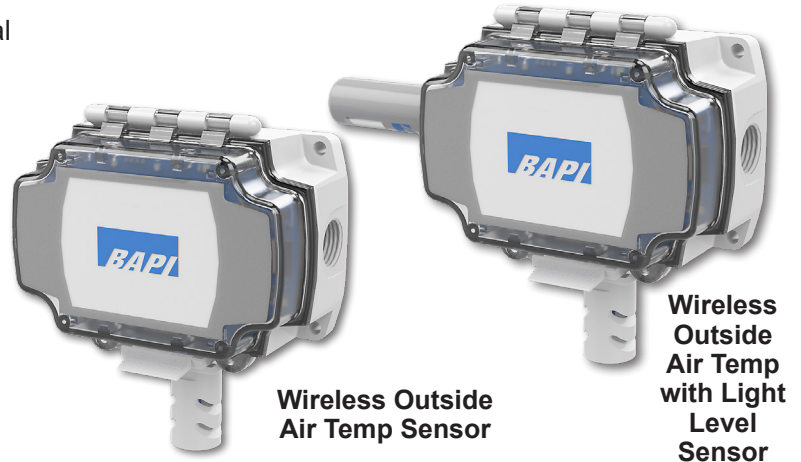

Associated Receiver or Gateway

RECEIVER (Wireless-to-Analog)

The wireless receiver from BAPI receives the data from one or more wireless sensors. The data is then transferred to the analog output modules and converted to an analog voltage or resistance. The receiver supports up to 32 sensors and up to 127 different analog output modules.



GATEWAY

The wireless gateway receives the data from one or more wireless sensors. The gateway then provides the data to the cloud via MQTT. The gateway also sends a confirmation signal to each sensor upon a successful reception of data. The gateway supports up to 32 sensors.



See BAPI's gateway instructions on the BAPI website (www.bapihvac.com/wp-content/uploads/50387_Wireless_BLE_Gateway.pdf) to establish communication between the sensors and gateway or the receiver instructions (www.bapihvac.com/wp-content/uploads/50335_Wireless_BLE_Receiver_AOM.pdf) to establish communication between the sensors and receiver.

Adjustable Settings

BAPI's wireless sensors have several settings that can be field adjusted to suit the needs of the installation. All settings are configured by either BAPI's cloud-based Wireless Asset Monitoring (WAM) or the receiver. (See the WAM or receiver instructions documents on the BAPI website for more information on adjusting the settings.)

Sample Rate/Interval – The time between when the sensor wakes up and takes a reading. The available values are 1 min or 5 min with the gateway, or 30 sec, 1 min, 3 min or 5 min with the receiver.

Transmit Rate/Interval – The time between when the sensor transmits the readings to the gateway or receiver. The available values are 1, 2, 3, 4, 5, 10, 15, 20 or 30 minutes, or 1, 6 or 12 hours with the gateway, or 1, 5, 10 or 30 minutes with the receiver.

Delta Δ Temperature – The change in temperature between a sample and the last transmission that will cause the sensor to override the transmit interval and immediately transmit the changed temperature. The available values are 0.1, 0.2, 0.3, 0.4, 0.5, 1, 2, 3, 4, 5 °F or °C with the gateway, and 1 or 3 °F or °C with the receiver.

Temperature Min/Max – The maximum or minimum temperature that will cause the sensor to override the transmit interval and immediately transmit a reading to the gateway. (Only available when using a gateway.)

Temperature Offset – Adjusts the temperature value being transmitted to match that of a calibrated reference device. The available values are $\pm 0.1, 0.2, 0.5, 1, 2, 3, 4$ or 5 °F or °C. (Only available when using a gateway.)

Initial Activation

Battery Power Units

The unit comes with two pre-installed batteries. To activate the unit, open the cover to access the batteries (Fig 1). Find the battery tab insulators and pull them out. Press the Service button and the Service LED should flash once to confirm power.

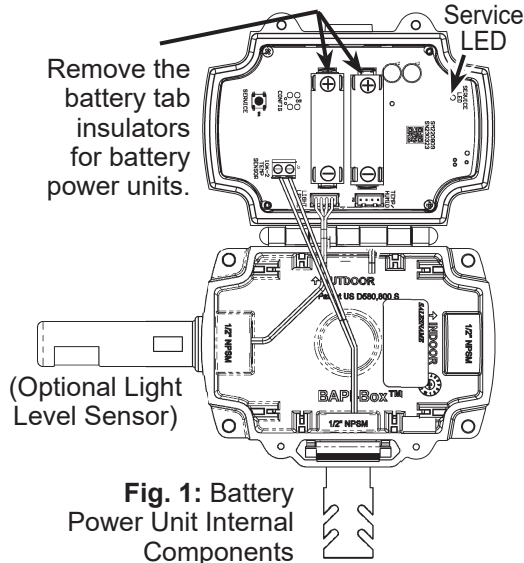

Fig. 1: Battery Power Unit Internal Components

Wire Power Units

To activate the unit, open the cover to access the circuit board and apply the 9 to 30 VDC or 24 VAC to the power terminals as shown.

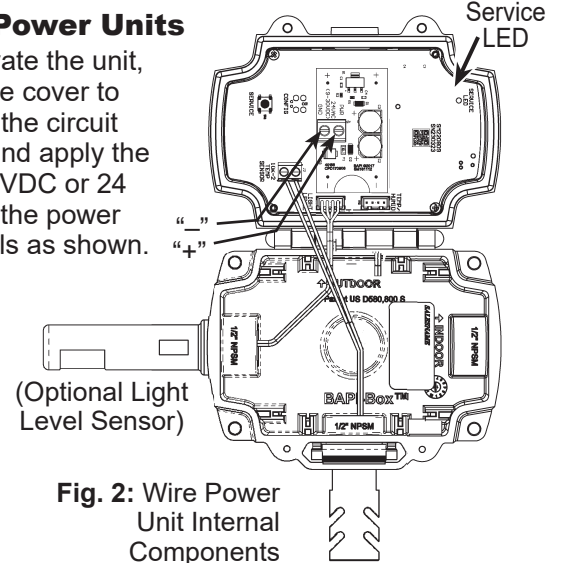

Fig. 2: Wire Power Unit Internal Components

Mounting

Outside Air sensor placement is critical to good performance. The sensor must be mounted in the shade away from building windows, doors or vents. They should never be in direct sunlight or you will have higher than expected temperature readings by as much as +30%. The ideal shaded location in the Northern hemisphere is on the North side of the building. In the Southern hemisphere the South side of the building is ideal.

The temperature or temp/humidity probe should always point down and be mounted a minimum of four feet above the ground or roof and be shaded.

For units with the optional light level sensor, make sure that the window portion is pointing downward and that other equipment on the building cannot physically or mechanically obstruct the sensor. Do not mount under awnings or other projections within 15 feet (4.5m).

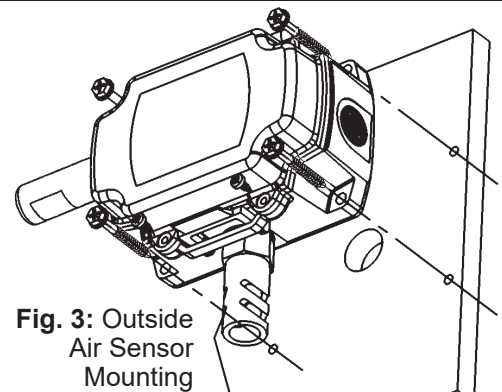

Fig. 3: Outside Air Sensor Mounting

Operation

Power the unit as described in "Initial Activation" section. Follow the gateway or receiver instructions for pairing the unit and changing the adjustable settings. (The instructions are available on the BAPI website.)

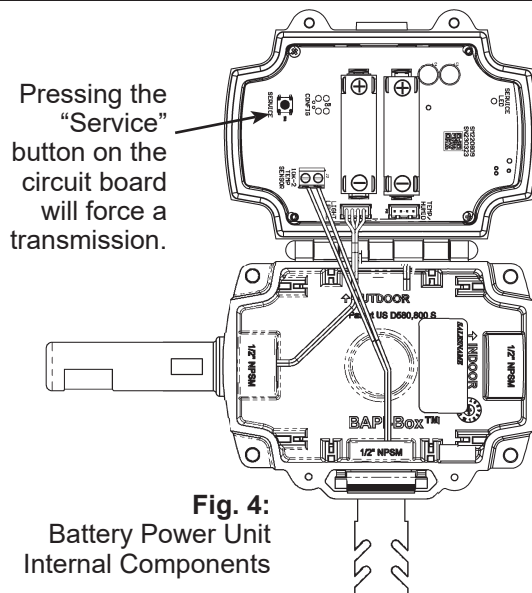

Fig. 4: Battery Power Unit Internal Components

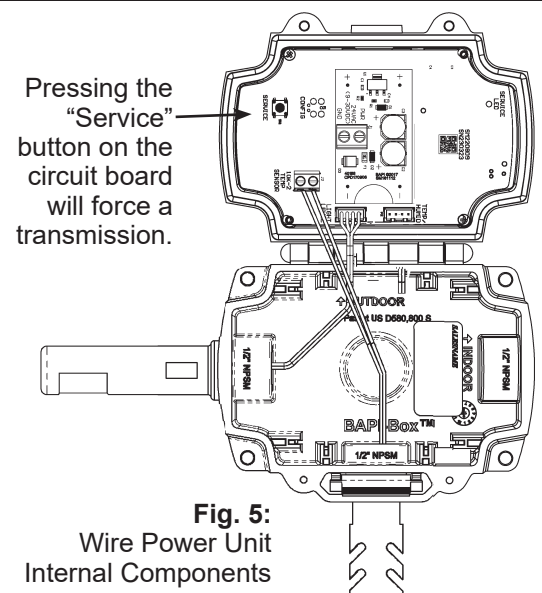

Fig. 5: Wire Power Unit Internal Components

Wireless Sensor Reset

Sensors remain paired to the gateway or receiver and output modules when power is interrupted or the batteries are removed. To break the bonds between them, the sensors need to be reset. To do this, press and hold the “Service Button” on the sensor for about 30 seconds. During those 30 seconds, the green LED will be off for about 5 seconds, then flash slowly, then begin flashing rapidly. When the rapid flashing stops, the reset is complete. The sensor can now be paired to a new receiver or gateway. To re-pair to the same receiver or gateway, you must reset the receiver or gateway. Output modules that were previously paired to the sensor do not need to be re-paired.

Onboard Memory

Sensor retains up to 16,000 readings should the communication become interrupted. The sensor only stores readings from missed transmissions and only when the sensor is paired to a gateway. Once communication is re-established with the gateway, the stored readings are transmitted and then erased from the sensor. The current reading and nine previous readings are sent at each transmit interval until the sensor is caught up. Temporarily shortening the transmit interval will allow the sensor to more quickly clear any stored readings.

Battery Replacement

Open the cover to access the batteries (Fig 6).

Remove the batteries from their holders and discard in an environmentally safe manner. Replace with new batteries in the correct orientation.

Battery Specifications:

Two 3.6V Lithium batteries:
(#14505, 14500 or equivalent)

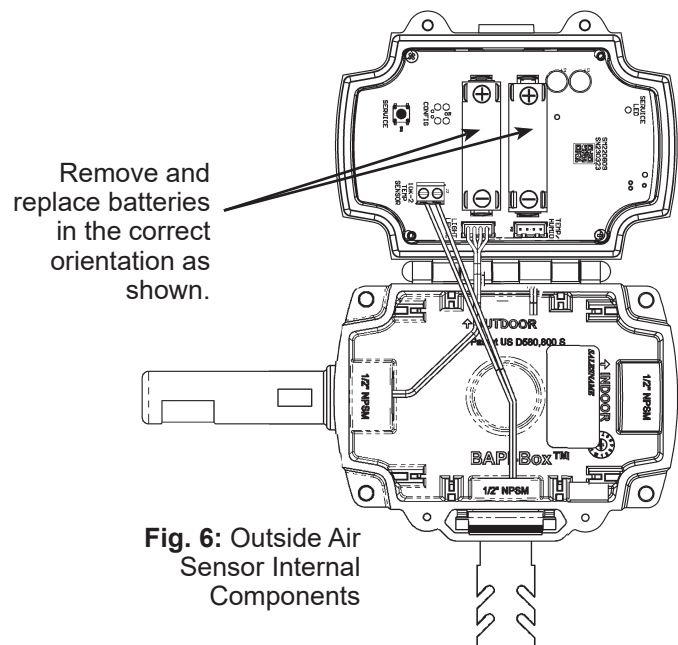

Fig. 6: Outside Air Sensor Internal Components

Diagnostics

Possible Problems:

Sensor is not communicating with the gateway or receiver, or the transmitted values are incorrect.

Possible Solutions:

Make sure the sensor is within range of the gateway or receiver.

Verify that the green LED on the sensor circuit board flashes when the “Service” button is pressed, indicating a transmission. If it does not flash, replace the batteries.

Verify that the sensor is properly paired to the gateway or receiver and analog output modules as described in the gateway or receiver instructions available on the BAPI website. Re-pair them if needed. If necessary, perform the “Wireless Sensor Reset” procedure as described above.



Wireless Outside Air Temperature, Barometric Pressure and Optional Light Level Sensor

Installation & Operations

50336_Wireless_BLE_Outside_Temp_LLV

rev. 10/29/24

Specifications

Battery Power:

Two included 3.6V 14505, 14500 or equiv. lithium batteries (Standard AA batteries are not compatible)

Wire Power: 9 to 30 VDC or 24 VAC, halfwave rectified

Sensor Accuracy:

Temp: $\pm 1.0^{\circ}\text{F}$ (0.55°C) from 32 to 158 $^{\circ}\text{F}$ (0 to 70 $^{\circ}\text{C}$)

Barometric Pressure: ± 2 mbar @ 25 $^{\circ}\text{C}$ ($0.40''\text{H}_2\text{O}$)

Light Level: 10 Lux + 10% of reading.

Temperature Range: -4 to 221 $^{\circ}\text{F}$ (-20 to 105 $^{\circ}\text{C}$)

Light Level Sensing Range: 0 to 64,000 lux

Transmission Distance: Varies by application*

Environmental Operation Range:

Temp: -4 to 149 $^{\circ}\text{F}$ (-20 to 65 $^{\circ}\text{C}$)

Humidity: 10 to 90%RH, non-condensing

Enclosure Rating and Material:

IP66, UV-Resistant Polycarbonate, UL94 V-0

Frequency: 2.4 GHz (Bluetooth Low Energy)

Receiver Sensitivity: -97 dBm

User Adjustable Settings:

Delta T (Temp): 0.1 $^{\circ}\text{F}/\text{C}$ to 5.0 $^{\circ}\text{F}/\text{C}$

Transmit Interval: 30 sec to 12 hour***

Sample Interval: 30 sec to 5 min***

Temp Offset: $\pm 0.1^{\circ}\text{F}/\text{C}$ to $\pm 3.0^{\circ}\text{F}/\text{C}$

Onboard Memory:

Sensor retains up to 16,000 readings should the communication become interrupted. If using a Gateway, the data is re-transmitted once communication is re-established.

*In-building range is dependent on obstructions such as furniture and walls and the density of those materials. In wide open spaces, the distance may be greater; in dense spaces, the distance may be less.

**Actual battery life is dependent on the sensor's adjustable settings and environmental conditions.

***The available transmit intervals and sample intervals are different depending on whether the system is using a gateway or a receiver.

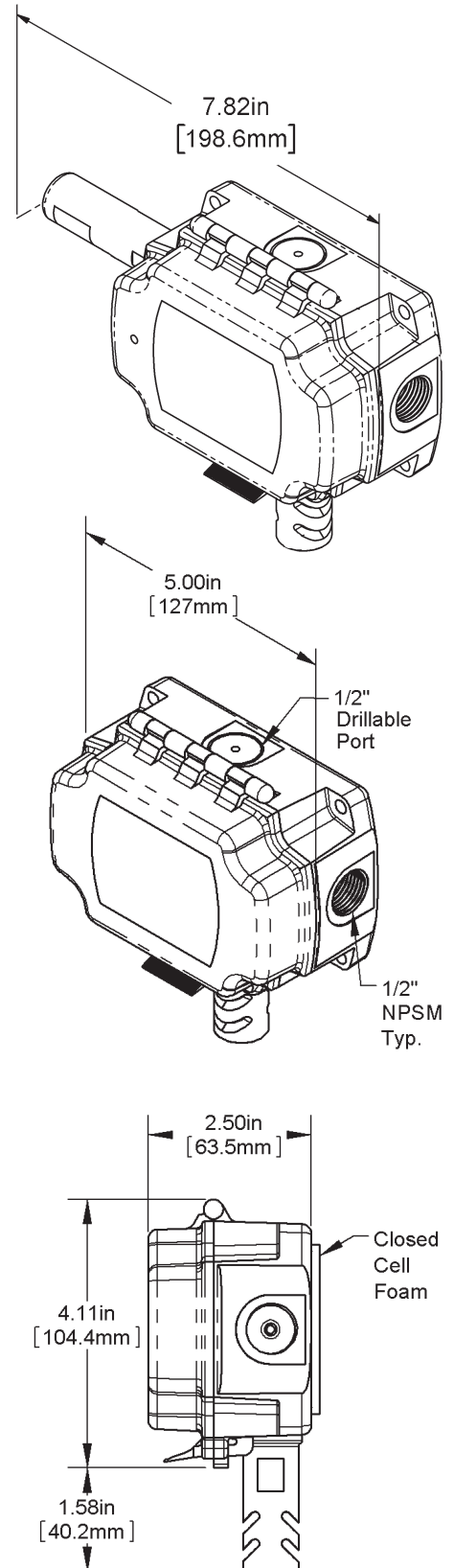

BAPI-Box Units Calculated Battery Life**		
Transmit Interval	Sample Rate	Estimated Life (years)
30 sec	30 sec	1.04
1 min	1 min	1.95
3 min	1 min	3.46
5 min	5 min	4.63
10 min	5 min	7.02

Specifications subject to change without notice.



Wireless Outside Air Temperature, Barometric Pressure and Optional Light Level Sensor

Installation & Operations

50336_Wireless_BLE_Outside_Temp_LLW

rev. 10/29/24

Agency Certifications

RoHS / Contains FCC ID: QOQGM210P / IC: 5123A-GM210 / Independent Communications Authority of South Africa

This device complies with Part 15 of the FCC Rules. Operation is subject to the following two conditions:

1. This device may not cause harmful interference, and
 2. This device must accept any interference received, including interference that may cause undesirable operation.
- Any changes or modifications not expressly approved by BAPI could void the user's authority to operate the equipment.

This device complies with Industry Canada (IC) license-exempt RSS standard(s). Operation is subject to the following two conditions.

This device may not cause interference.

This device must accept any interference, including interference that may cause undesired operation of the device.

Le présent appareil est conforme aux CNR d'Industrie Canada applicables aux appareils radio exempts de licence. L'exploitation est autorisée aux deux conditions suivantes.

L'appareil ne doit pas produire de brouillage.

L'appareil doit accepter tout brouillage radioélectrique subi, même si le brouillard est susceptible d'en compromettre le fonctionnement.

