

### Identification and Overview

BAPI's EZ Low Pressure Sensor is a true differential pressure transmitter that provides  $\pm 1$  inches WC ( $\pm 250$  Pascals) in 10 field selectable ranges (see specifications). BAPI's EZ enclosure is designed for DIN rail, Snaptrack or surface mounting. Five output ranges of 0 to 5, 1 to 5, 0 to 10 and 2 to 10 VDC and 4 to 20 mA are also field selectable for all pressure ranges. The wiring terminal block is pluggable. Pressure units of inches of Water Column or Pascals are field selectable.

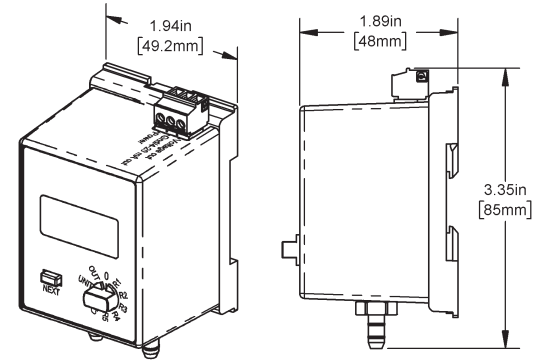

Fig. 1: EZ Pressure Sensor

### Mounting

The EZ Mount Base has mounting tabs that can be extended or pushed in for the three mounting methods.

#### DIN Rail Mounting, Figs 2-3:

- Pull out the blue mounting tabs.
- Catch the EZ mount hook on DIN rail as shown in Fig 3.
- Rotate the EZ pressure module down until the bottom mounting tab snaps into place on the DIN rail.
- Connect wires and pressure lines as needed.

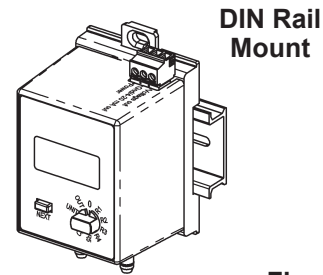

Fig. 2: DIN Rail Mounting with tabs out

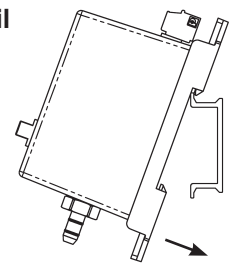

Fig. 3: Catch the EZ Mount hook on the edge of the DIN Rail, then rotate into place

#### Snaptrack Mounting, Fig 4:

- Push in the blue mounting tabs.
- Snap the EZ Mount base into the board slots in the 2.75 inch snaptrack.
- Connect wires and pressure lines as needed.

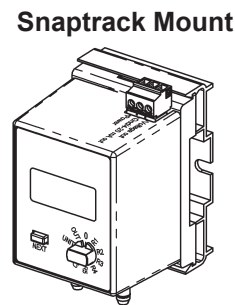

Fig. 4: Snaptrack Mounting with tabs in

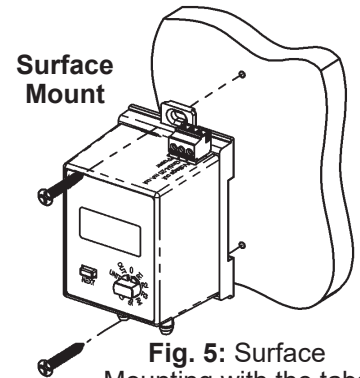

Fig. 5: Surface Mounting with the tabs out

#### Surface Mounting, Fig 5:

- Pull out the blue mounting tabs.
- Place the EZ Pressure unit against the surface and mark the screw holes.
- Drill 1/8" pilot holes for #8 flathead screws.
- Screw unit to the surface. The holes in the blue mounting tabs are elongated to allow for alignment.
- Connect wires and pressure lines as needed.

### Pressure Connections

The Pressure ports are 3/16" (4.75mm) barbed fittings.

- Connect the high pressure to the port labeled High.
- Connect the low pressure to the port labeled Low.

The output will be the pressure difference between the high and low port.

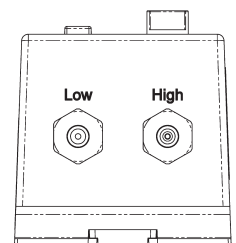

Fig. 6: Pressure Port Connections

### Wiring Termination



BAPI recommends wiring the product with power disconnected. Proper supply voltage, polarity and wiring connections are important to a successful installation. Not observing these recommendations may damage the product and void the warranty.

**Table 1: EZ Pressure Sensor Termination**

| Output Signal | Power Terminal              | Gnd/4-20mA Terminal                          | Voltage Output Terminal                       |
|---------------|-----------------------------|--|---|
| 4 to 20 mA    | 8 to 40 VDC*                | 4 to 20 mA Signal To Controller Analog Input | Not Used                                      |
| 0 to 5 VDC    | 7 to 40 VDC or 6 to 28 VAC  | To Controller Ground                         | 0 to 5 VDC Signal To Controller Analog Input  |
| 1 to 5 VDC    | 7 to 40 VDC or 6 to 28 VAC  | To Controller Ground                         | 1 to 5 VDC Signal To Controller Analog Input  |
| 0 to 10 VDC   | 12 to 40 VDC or 9 to 28 VAC | To Controller Ground                         | 0 to 10 VDC Signal To Controller Analog Input |
| 2 to 10 VDC   | 12 to 40 VDC or 9 to 28 VAC | To Controller Ground                         | 2 to 10 VDC Signal To Controller Analog Input |

#### 4 to 20 mA, “Two Wire” Operation

- Connect the EZ Pressure’s “Power” terminal to a DC voltage of 8 to 40 VDC\*.
- Connect the “Gnd/4-20 mA Out” terminal to a 4 to 20 mA input on your controller.
- The “Voltage Out” terminal is not used for 4 to 20 mA signaling.

#### 0 to 5, 1 to 5, 0 to 10 or 2 to 10 V, “Three Wire” Operation

- Connect the EZ Pressure’s “Power” terminal to:
  - 7 to 40 VDC or 6 to 28 VAC (for 0 to 5 or 1 to 5 VDC output units).
  - 12 to 40 VDC or 9 to 28 VAC (for 0 to 10 or 2 to 10 VDC output units).
- Connect the terminal labeled “Gnd/4-20 mA Out” to the controller’s ground.
- Connect the “Voltage Out” terminal to an analog input configured for voltage input.

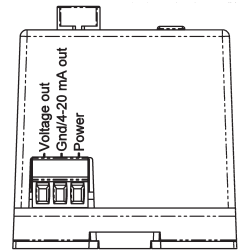

**Fig. 7: Wiring terminations**

**Note:** The terminals use a rising block screw terminal to hold the wires. It is possible for the block to be in a partially up position allowing the wire to be inserted under the block. Be sure that the connector screws are turned fully counterclockwise before inserting the wire. Lightly tug on each wire after tightening to verify proper termination.

### Front Panel Operation

The rotary switch and the NEXT button shown in Fig. 8 are used to operate and configure the unit as described on page 3.

#### INITIAL START-UP

For maximum performance and to ensure that accuracy specifications are met, the Initial Start-Up procedure must be followed. Before using the sensor, please wait 24 hours (with no pressure applied) to allow the sensor to acclimate to its respective environment. After the 24 hour acclimation period has been completed, the device should be powered, deadheaded and in its desired range of measure for 60 minutes to reach its normal internal operation temperature. Then, the auto-zero process can begin.

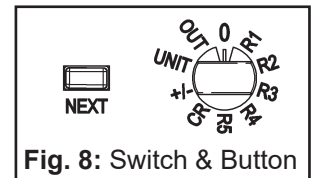

**Fig. 8: Switch & Button**

#### AUTO-ZERO FUNCTION (Table 2)

Auto-Zero after the initial setup, changing mounting orientation or changing any settings. For most applications, perform an auto-zero whenever it appears that the sensor has drifted. For critical applications, the unit should be zeroed 2-3 times a year. Follow the steps below to auto-zero the unit. If either the analog output or the directionality of the output is changed, for maximum accuracy, the device should be powered, deadheaded and in its desired range of measure for 60 minutes before an auto-zero.

- Connect the high and low ports together with a short length of tubing without kinks.
- Place the rotary switch into the “0” position. The display will show “Aut0”.
- Press the NEXT button. The display will show a series of progress bars starting with one bar and ending with four.
- When the auto-zero is complete, the display will show “donE” for about 4 seconds, then “Aut0”.
- Return the rotary switch to the desired pressure range (see Pressure Range Select).

| Rotary Switch Position | Initial Display | After Pushing NEXT button | When Complete |
|------------------------|-----------------|---------------------------|---------------|
|                        | <b>Aut0</b>     | <b>— — — —</b>            | <b>donE</b>   |

Front Panel Operation Continued on next page...

### Front Panel Operation continued....

#### OUTPUT RANGE SELECT (Table 3)

- Place the rotary switch into the "OUT" position.
- Press the NEXT button until the desired output range is showing on the display.
- Return the rotary switch to the desired pressure range (see Pressure Range Select).

| Rotary Switch Position | 4 to 20 mA Output | 0 to 5 VDC Output | 1 to 5 VDC Output | 0 to 10 VDC Output | 2 to 10 VDC Output |
|------------------------|-------------------|-------------------|-------------------|--------------------|--------------------|
|                        | 4-20              | 0-5               | 1-5               | 0-10               | 2-10               |

#### PRESSURE RANGE SELECT (Table 4)

Rotate the rotary switch to any of the positions labeled "R1" through "R5" or "CR" for a Custom Range. The display will show the pressure range for 2 to 4 seconds, and then the display will show the differential pressure across the ports.

Note: Custom Range units will have the pressure range printed on the label. Be sure to return the rotary switch to the "CR" position after auto-zeroing or switching outputs on the custom range units.

#### UNI-DIRECTIONAL OR BI-DIRECTIONAL SELECT (Table 5)

All pressure ranges can be made uni-directional or bi-directional.

- Place the rotary switch into the "+/-" position. The directional mode will show on the display.
- Press the NEXT button until the desired mode is showing on the display.
- Return the rotary switch to the desired pressure range.

| Rotary Switch Position | Inches W.C.        | Pascals |
|------------------------|--------------------|---------|
|                        | 0.10 <sup>in</sup> | 30 Pa   |
|                        | 0.25 <sup>in</sup> | 50 Pa   |
|                        | 0.50 <sup>in</sup> | 100 Pa  |
|                        | 0.75 <sup>in</sup> | 175 Pa  |
|                        | 1.00 <sup>in</sup> | 250 Pa  |

| Rotary Switch Position | Uni-Directional Pressure | Bi-Directional Pressure |
|------------------------|--------------------------|-------------------------|
|                        | Un                       | -b                      |

#### UNIT MODE SELECT (Inches WC or Pascals)

You have the ability to toggle between Inches W.C. and Pascals by pressing the next button when the rotary switch is in the "UNIT" position. When the unit is measuring in Inches W.C., the unit will display in inches with an "In" after the number. When the unit is measuring in Pascals, the unit will display in Pascals with a "Pa" after the number.

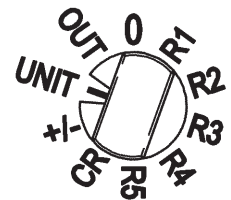

Fig. 9: Rotary Switch Position for Unit Mode Selection

### Typical Applications

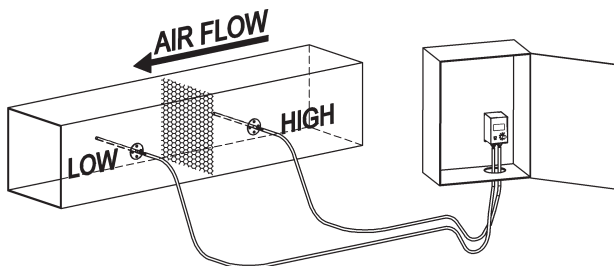

Fig. 10: Air filter pressure drop monitoring with the EZ Low Pressure Sensor mounted in a panel with two static pressure probes (ZPS-ACC07) in the duct.

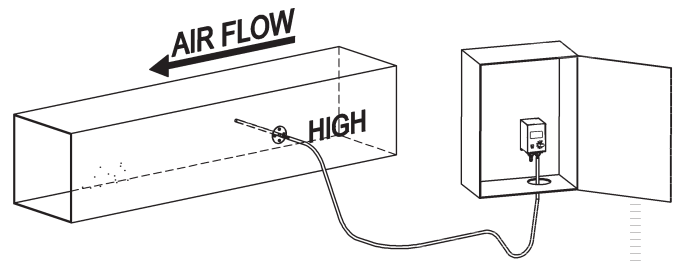

Fig. 11: Duct static pressure monitoring with the BAPI EZ Low Pressure Sensor mounted in a panel with a static probe (ZPS-ACC07) in the duct.

**NOTE:** Best practice is to form a drip loop in the tubing to prevent condensation from reaching the sensor.



# EZ Pressure Sensor, Low Pressure Ranges

## Installation and Operation Instructions

49583\_ins\_EZPS\_Low\_Range.pdf

rev. 06/09/2025

### Troubleshooting

#### POSSIBLE PROBLEMS:

Display does not light

Output stuck either high or low or not tracking pressure properly.

#### POSSIBLE SOLUTIONS:

- Check power connections for proper power (see specifications below).

- Remove pressure from ports and perform auto-zero procedure described on page 2.

### Specifications

#### Power:

- 8 to 40 VDC\* (4 to 20 mA Output)
- 7 to 40 VDC or 6 to 28 VAC (0 to 5 or 1 to 5 VDC Output)
- 12 to 40 VDC or 9 to 28 VAC (0 to 10 or 2 to 10 VDC Output)

#### Power Consumption:

- 20 mA max DC only at 4 to 20 mA Output
- 4.9 mA max DC at 0 to 5 or 0 to 10 VDC Output
- 0.12 VA max AC at 0 to 5 or 0 to 10 VDC Output

#### Load Resistance:

- 4 to 20 mA Output 850Ω Maximum @ 25 VDC
- 0 to 5, 1 to 5, 0 to 10, 2 to 10 VDC Output 6KΩ min.

#### Accuracy:

±0.25% FS at 77°F (25°C) or ±0.005" WC (±1.24 Pa)

#### Total Error Band\*\*:

±1.25% FS or ±0.025" WC (±6.22 Pa)

#### Temp Hysteresis & Stability:

±0.35% at 77°F (25°C) for 1000 Hours

#### Overpressure: Proof 270" WC (67 kPa)

#### Field Selectable Outputs:

4 to 20 mA, 0 to 5 V, 1 to 5 V, 0 to 10 V, 2 to 10 V

#### Media: Clean, dry, non-corrosive gases

#### Wiring: 3 wires (2 wires for 4 to 20 mA output)

#### Env. Operating Range: 14 to 131°F (-10 to 55°C)

#### Storage Temp: -4 to 140°F (-20 to 60°C)

#### Humidity: 0 to 95% RH, non-condensing

#### Port Size: 3/16" barb (4.75mm)

**Enclosure Material:** ABS Plastic, UL94 V-0

**Mounting:** DIN Rail, Snaptrack or Surface

**Agency:** RoHS, UL, CE EN 61326-1:2013 EMC

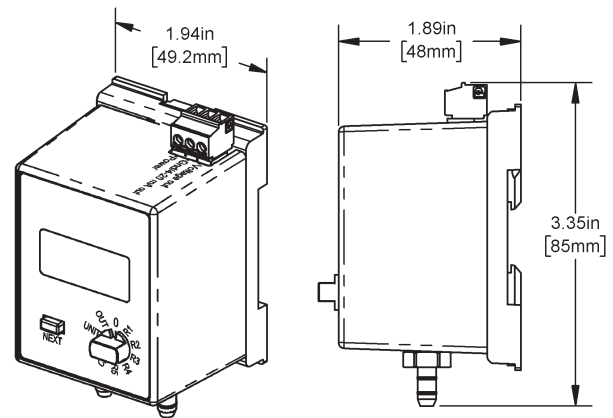

\*The minimum input voltage for a 4 to 20 mA unit varies based on the load or input impedance of the controller it is connected to. The equation is shown below:

$$(0.02 \times \text{Controller Load Impedance}) + 8 = \text{Minimum Voltage}$$

Example: Controller Load Impedance of 250Ω

$$(0.02 \times 250) = 5 \quad | \quad 5 + 8 = 13 \text{ VDC minimum voltage}$$

\*\*Total Error Band is the typical accuracy within the compensated temperature range of 32 to 122°F (0 to 50°C). The Total Error Band covers non-linearity, hysteresis and thermal effect on span. This is only valid after the initial startup and auto-zero process has been performed.

Table 6: Low Pressure Ranges

| Inches of Water Column (WC) Ranges |            |       |          | Pascal Ranges |             |       |          |
|------------------------------------|------------|-------|----------|---------------|-------------|-------|----------|
| Range                              | Pressure   | Range | Pressure | Range         | Pressure    | Range | Pressure |
| 51                                 | 0 to 0.10" | 56    | ± 0.10"  | 61            | 0 to 30 Pa  | 66    | ± 30 Pa  |
| 52                                 | 0 to 0.25" | 57    | ± 0.25"  | 62            | 0 to 50 Pa  | 67    | ± 50 Pa  |
| 53                                 | 0 to 0.50" | 58    | ± 0.50"  | 63            | 0 to 100 Pa | 68    | ± 100 Pa |
| 54                                 | 0 to 0.75" | 59    | ± 0.75"  | 64            | 0 to 175 Pa | 69    | ± 175 Pa |
| 55                                 | 0 to 1.00" | 60    | ± 1.00"  | 65            | 0 to 250 Pa | 70    | ± 250 Pa |

Specifications subject to change without notice.