

Overview

Duct and Outside Air Humidity Transmitters come in $\pm 2\%RH$ or $\pm 3\%RH$ accuracies and an optional temperature sensor. The temperature sensor can be either a Thermistor or RTD. It can be ordered with a Weatherproof (WP), BAPI-Box (BB) or BAPI-Box 2 (BB2) Enclosure. The transmitter can be wired for 0 to 5, 1 to 5, 0 to 10 or 2 to 10 VDC output or a loop powered 4 to 20mA output.

Duct Unit Mounting

Mount at least 3 duct diameters from humidifiers in the center of the duct wall. Drill a 1 inch hole for the probe in the duct and use two number 8 sheet metal screws to attach the sensor to the duct. Center the probe in its mounting hole. Be sure that the foam seals the hole, do not over tighten the screws.

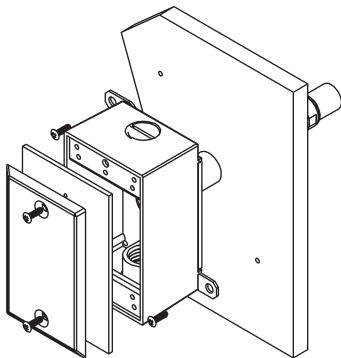

Fig. 1: Duct Humidity in a Weatherproof (WP) Enclosure

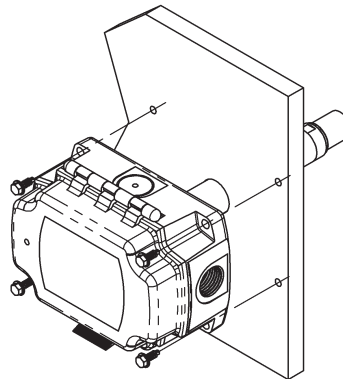

Fig. 2: Duct Humidity in a BAPI-Box (BB) Enclosure

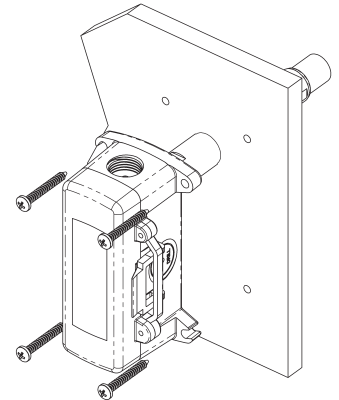

Fig. 3: Duct Humidity in a BAPI-Box 2 (BB2) Enclosure

Outside Air Mounting

Mount in a permanently shaded area away from windows and doors. Do not mount in direct sunlight. Mount with the sensor probe pointed down. Drill a hole large enough for your sensor cable through your mounting surface. Mount the unit to the surface with the wiring knock out centered over the wiring hole. Pull the wiring into the unit and terminate using sealant filled connectors. Best practice is to seal the wiring hole with caulk after the wiring is installed. Be sure that the foam on the back of the unit makes a good weather tight seal.

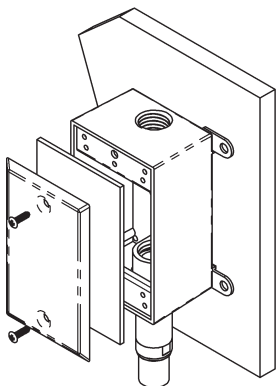

Fig. 4: Outside Humidity in a Weatherproof (WP) Enclosure

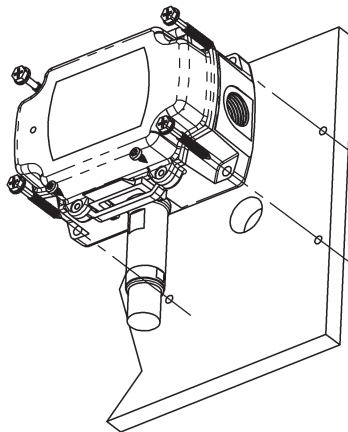

Fig. 5: Outside Humidity in a BAPI-Box (BB) Enclosure

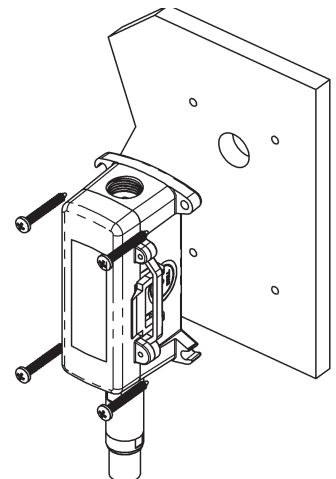

Fig. 6: Outside Humidity in a BAPI-Box 2 (BB2) Enclosure

Wiring and Termination

BAPI recommends using twisted pair of at least 22AWG and sealant filled connectors for all wire connections. Larger gauge wire may be required for long runs. All wiring must comply with the National Electric Code (NEC) and local codes.

Do NOT run this device's wiring in the same conduit as AC power wiring of NEC class 1, NEC class 2, NEC class 3 or with wiring used to supply highly inductive loads such as motors, contactors and relays. BAPI's tests show that fluctuating and inaccurate signal levels are possible when AC power wiring is present in the same conduit as the signal lines. If you are experiencing any of these difficulties, please contact your BAPI representative.



BAPI recommends wiring the product with power disconnected. Proper supply voltage, polarity, and wiring connections are important to a successful installation. Not observing these recommendations may damage the product and will void the warranty.

Wire Color	Purpose	Note
White	Not Used	Not Used
Black	Humidity Output	4 to 20mA, To Analog Input of Controller
Red	Power	7 to 40VDC

Wire Color	Purpose	Note
White	Humidity Output	0 to 5 or 1 to 5VDC, To Analog Input of Controller
Black	GND (Common)	Ground for Power and Humidity Output
Red	Power	7 to 40VDC or 18 to 32VAC

Wire Color	Purpose	Note
White	Humidity Output	0 to 10 or 2 to 10VDC, To Analog Input of Controller
Black	GND (Common)	Ground for Power and Humidity Output
Red	Power	13 to 40VDC or 18 to 32VAC

Thermistors		Platinum RTDs - 2 Wire	
1.8K Ω	Orange/Red	100 Ω	Red/Red
2.2K Ω	Brown/White	1K Ω	Orange/Orange
3K Ω	Yellow/Black	Nickel RTD	
3.25K Ω	Brown/Green	1K Ω	Green/Green
3.3K Ω	Yellow/Brown	Silicon RTD	
10K-2 Ω	Yellow/Yellow	2K Ω	Brown/Blue
10K-3 Ω	Yellow/Red	Platinum RTDs - 3 Wire	
10K-3(11K) Ω	Yellow/Blue	100 Ω	Red/Red/Black*
20K Ω	White/White	1K Ω	Orange/Orange/Black*
47K Ω	Yellow/Orange	*In the 3-Wire RTD sensors listed above, the two wires of similar color are connected together.	
50K Ω	White/Blue		
100K Ω	Yellow/White		

Additional sensors are available so your sensor may not be listed on this table.

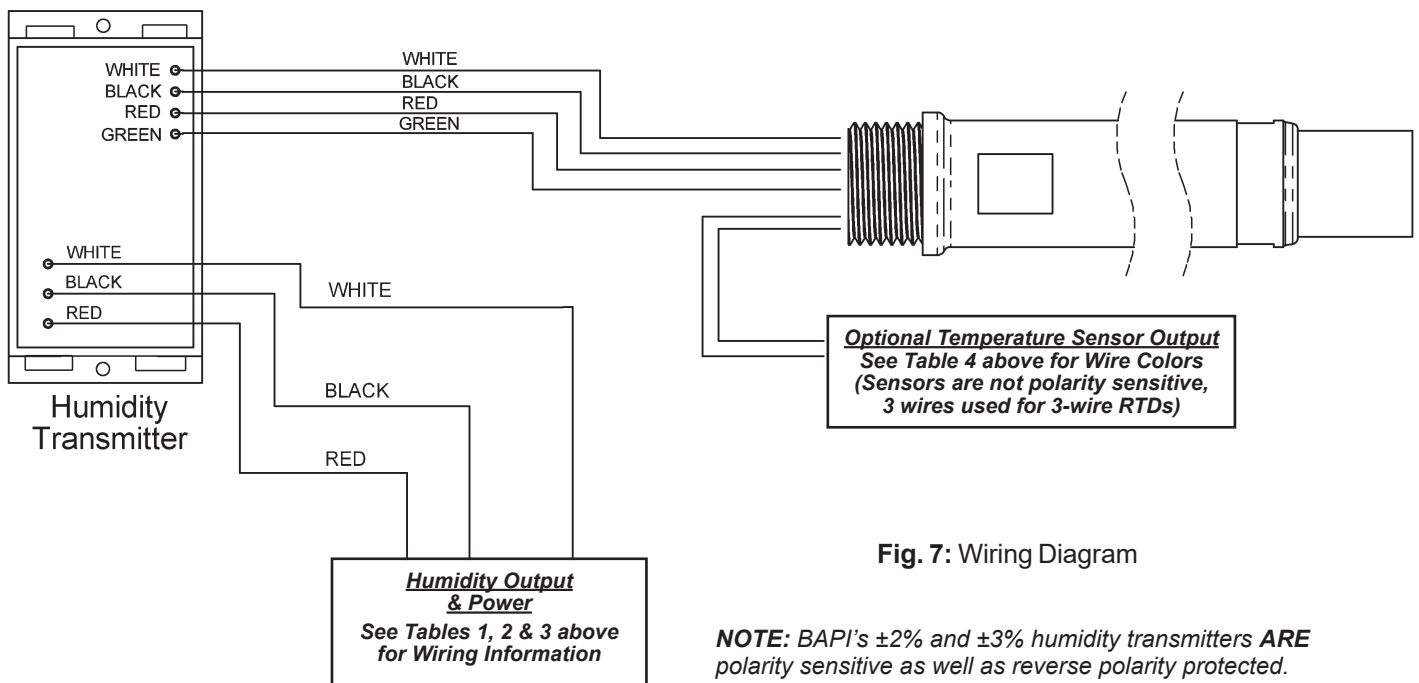

Fig. 7: Wiring Diagram

NOTE: BAPI's $\pm 2\%$ and $\pm 3\%$ humidity transmitters **ARE** polarity sensitive as well as reverse polarity protected.



Duct and Outside Air Humidity with Optional Temperature Sensor

Installation and Operating Instructions

49483_ins_duct_OSA_humidity

rev. 10/06/25

Specifications

Power:

- 10 to 35 VDC For 0 to 5 or 1 to 5 VDC or 4 to 20 mA Humidity Outputs
- 15 to 35 VDC For 0 to 10 or 2 to 10 VDC Humidity Output
- 12 to 27 VAC For 0 to 5 or 1 to 5 VDC Humidity Output
- 15 to 27 VAC For 0 to 10 or 2 to 10 VDC Humidity Output

Power Consumption:

- 22 mA max. DC For 0 to 5 or 1 to 5 VDC or 4 to 20 mA Humidity Outputs
- 6 mA max. DC For 0 to 10 or 2 to 10 VDC Humidity Outputs
- 0.53 VA max. AC For All Humidity Output

Sensor:

- Humidity..... Capacitive Polymer
- Drift 0.5% per year
- Response time..... < 5 seconds in moving air
- RH Linearity..... Negligible, factory corrected linear from 10 to 80% RH
- RH Hysteresis Factory corrected to <1%
- Opt. Temp..... Passive RTD or Thermistor

System Accuracy:

- 2% RH ±2% (10 to 80% RH @ 25°C), ±3% (80 to 90% RH @ 25°C), Non-condensing
- 3% RH ±3% (10 to 90% RH @ 25°C), Non-condensing
- Thermistor ±0.36°F (0.2°C) from 32 to 158°F (0 to 70°C) - High accuracy units are available
- RTD ±0.55°F (0.31°C) @ 32°F (0°C) - High accuracy units are available

Filter: 80 micron sintered stainless steel filter

Output: Selectable via wiring detail

- Humidity..... 0 to 5, 1 to 5, 0 to 10 or 2 to 10VDC or 4 to 20mA at 0 to 100% RH
- Opt. Temp..... Resistance RTD or Thermistor

Humidity Output Impedance:

- Current 700Ω@ 24VDC, Voltage drop is 10VDC
(Supply Voltage DC – Transmitter voltage drop 10VDC) / 0.02 Amps = Max load Impedance
- Voltage..... 10KΩ

Probe Length:

- Duct 5.3" (13.5cm) Duct Insertion, 1" diameter
- Outside Air..... 2.4" (6.1cm) Below Enclosure, 1" diameter

Dimensions: W x H x D

- Weatherproof (WP) 2.75" x 4.5" x 2.2", (70 x 114 x 55 mm)
- BAPI-Box (BB) 4.15" x 5" x 2.5", (105.4 x 127 x 63.5mm)
- BAPI-Box 2 (BB2) 4.9" x 2.8" x 2.35", (124.8 x 71.6 x 59.7mm)

Termination: Open wire

- Crimp 18 to 26 AWG with Sealant Filled Crimp Connector (BA/SFC1000-x00)
- Wire Nut..... 26 to 16 AWG with Sealant Filled Wire Nut (BA/SFC2000-x00)

Enclosure Material:

- Weatherproof (WP)..... Cast Aluminum
- BAPI-Boxes (BB, BB2) Polycarbonate, UV resistant

Enclosures Ratings:

- Weatherproof (WP)..... NEMA-3R
- BAPI-Boxes (BB, BB2) NEMA-4, IP66, UL94V-0

Environmental Operation Range: -40° to 158°F (-40° to 70°C) • 0% to 100% RH

Agency: CE EN 61326-1:2013 EMC (Industrial Electromagnetic Environment), RoHS

Specifications subject to change without notice.



Filter Care

A sintered filter protects the humidity sensor from various airborne particles and may need periodic cleaning. To do this, gently unscrew the filter from the probe. Rinse the filter in warm soapy water and rinse until clean. A nylon brush may be used if necessary. Gently replace the filter by screwing it back into the probe. The filter should screw all the way into the probe. Hand tighten only. If a replacement filter is needed, call BAPI.

BA/HDOFS3: Stainless Steel Sintered Filter Replacement for Outside Air Units

Humidity Diagnostics

Possible Problems:

- Unit will not operate
- Humidity output is at its maximum
- Humidity output is at its minimum
- Humidity reading in controller's software appears to be off by more than the specified accuracy

Possible Solutions:

- Check for proper supply power. (See page 2 for wiring diagram and power specifications)
- Make sure the humidity sensor is wired properly.
- Verify humidity with a reference sensor. If humidity drops to 5% or below in the environment, the output will go to the maximum value.
- Make sure the humidity sensor is wired properly.
- Check all software parameters
- Determine if the sensor is exposed to an external air source different from the intended measured environment or reference device.
- Check the Humidity transmitter output against a calibrated reference such as a 2% accurate hygrometer. Measure the humidity at the sensor's location using the reference meter, then calculate the humidity transmitter output using the humidity formula at left. Compare the calculated output to the actual humidity transmitter output (see the wiring diagram on page 2 for the humidity transmitter output wire colors). If the calculated output differs from the humidity transmitter output by more than 5%, contact BAPI technical support.

Output	Humidity Formula
4 to 20mA	$\%RH = (mA-4)/0.16$
0 to 5VDC	$\%RH = V/0.05$
1 to 5VDC	$\%RH = (V-1)/0.04$
0 to 10VDC	$\%RH = V/0.1$
2 to 10VDC	$\%RH = (V-2)/0.08$

Temperature Diagnostics

Possible Problems:

Controller reports Incorrect temperature

Possible Solutions:

- Confirm the input is set up correctly in the controller's software
- Verify that the sensor wires are not physically shorted or open
- Check wiring for proper termination
- Measure the temperature at the temperature sensor's location using an accurate temperature standard. Disconnect the temperature sensor wires and measure the temperature sensor's resistance with an ohmmeter. Compare the temperature sensor's resistance to the appropriate temperature sensor table on the BAPI website. If the measured resistance is different from the temperature table by more than 5%, call BAPI technical support. BAPI's web site is found at www.bapihvac.com; click on "Resource Library" and "Sensor Specs" then click on the type of sensor you have.

Humidity Output DIP Switch Note:

The transmitter circuit board may have a three-position DIP switch that controls the humidity output value. This switch is set at the factory at the time of the order. The settings of the switch are shown at right in case you want to change them in the field. Be aware that the power requirements for the unit change depending on the humidity output value. See the specifications section for power requirements.

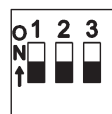

0-5Vout

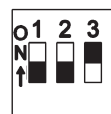

0-10Vout

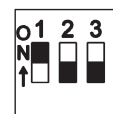

4-20mAout

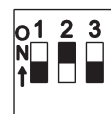

1-5Vout

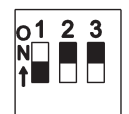

2-10Vout

The black square represents the switch position, i.e., the "0-5 Vout" has all switches in the "off" position