



BAPI-Stat "Quantum Prime" Temp & Humidity Sensor

Installation & Operating Instructions

41148_ins_quantum_prime_hum

rev. 03/06/24

Overview and Identification

The BAPI-Stat "Quantum Prime" is designed for operating rooms, clean rooms and elder care facilities. It features a large display and membrane keypad for wipedown cleaning. It is available with temperature and humidity measurement, temperature and humidity setpoint and occupant override.

The unit includes a number of field adjustments including °F or °C display, temperature and humidity offset and setpoint lockout. The display can also be set to show a large temperature and small %RH reading or a large %RH and a small temperature reading when 4 buttons are present. This unit can be configured with up to four transmitted variables. Contact your BAPI representative for details.

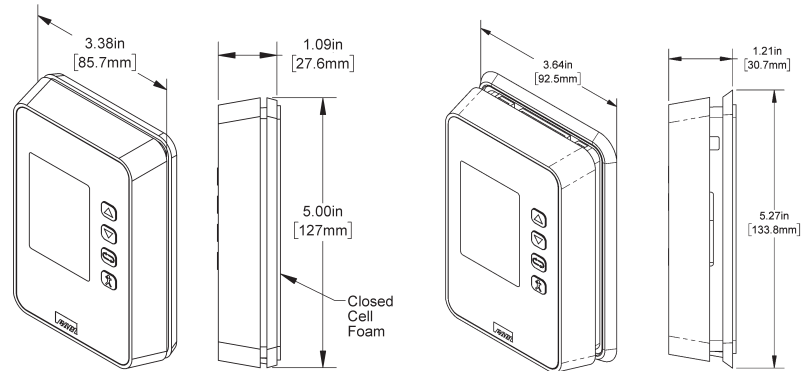

Fig. 1: BAPI-Stat "Quantum Prime" Temperature and Humidity Sensor (standard mounting base at left and 60mm mounting base for European wall boxes with 60mm mounting centers at right)

Mounting

JUNCTION BOX

1. Pull the wire through the wall and out of the junction box, leaving about six inches free. Pull the wire through the hole in the base plate.
2. Secure the backplate to the box using the #6-32 x 1/2 inch mounting screws provided.
3. Terminate according to the guidelines in the **Termination** section.
4. Attach cover by latching it to the top of the base and rotating the cover down. Secure the cover by backing out the lockdown screw using a 1/16" allen wrench until it is flush with the bottom of the cover.

DRYWALL MOUNTING

1. Place the base plate against the wall where you want to mount the sensor. mark out the two mounting holes and the area where the wires will come through the wall.
2. Drill two 3/16" holes in the center of each marked mounting hole. Insert a drywall anchor into each hole.
3. Drill one 1/2" hole in the middle of the marked wiring area.
4. Pull the wire through the wall and out the 1/2" hole, leaving about six inches free. Pull the wire through the hole in the base plate.
5. Secure the base to the drywall anchors using the #6 x 1" mounting screws provided.
6. Terminate the unit according to the guidelines in the **Termination** section.
7. Attach cover by latching it to the top of the base and rotating the cover down. Secure the cover by backing out the lockdown screw using a 1/16" allen wrench until it is flush with the sides of the cover.

Note: The mixing of room air and air from within the wall cavity can lead to condensation, erroneous readings and sensor failure. To prevent this, BAPI recommends sealing the conduit to the junction box with fiberglass insulation.

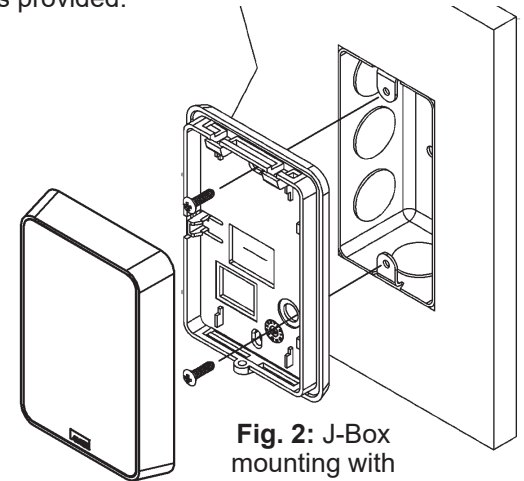

Fig. 2: J-Box mounting with standard base

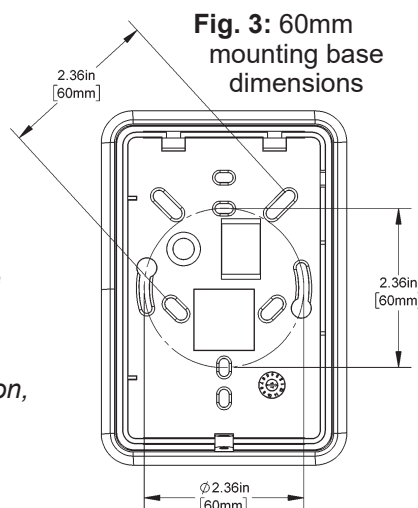

Fig. 3: 60mm mounting base dimensions

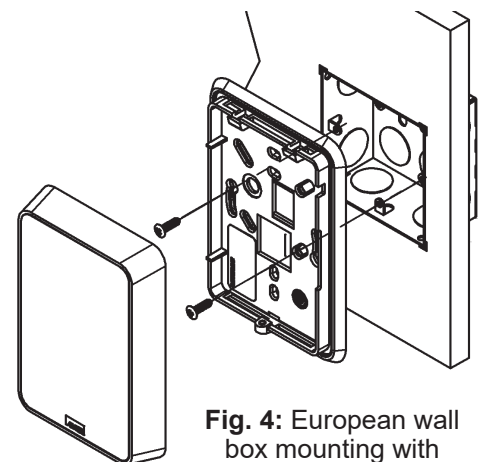

Fig. 4: European wall box mounting with 60mm base



BAPI-Stat “Quantum Prime” Temp & Humidity Sensor

Installation & Operating Instructions

41148_ins_quantum_prime_hum

rev. 03/06/24

Termination

BAPI recommends using twisted pair of at least 22 AWG. Larger gauge wire may be required for long runs. All wiring must comply with the National Electric Code (NEC) and local codes. **Do NOT** run this device’s wiring in the same conduit as AC power wiring of NEC class 1, NEC class 2, NEC class 3 or with wiring used to supply highly inductive loads such as motors, contactors and relays. BAPI’s tests show that fluctuating and inaccurate signal levels are possible when AC power wiring is present in the same conduit as the signal lines.



BAPI recommends wiring the product with power disconnected. Proper supply voltage, polarity, and wiring connections are important to a successful installation. Not observing these recommendations may damage the product and will void the warranty.

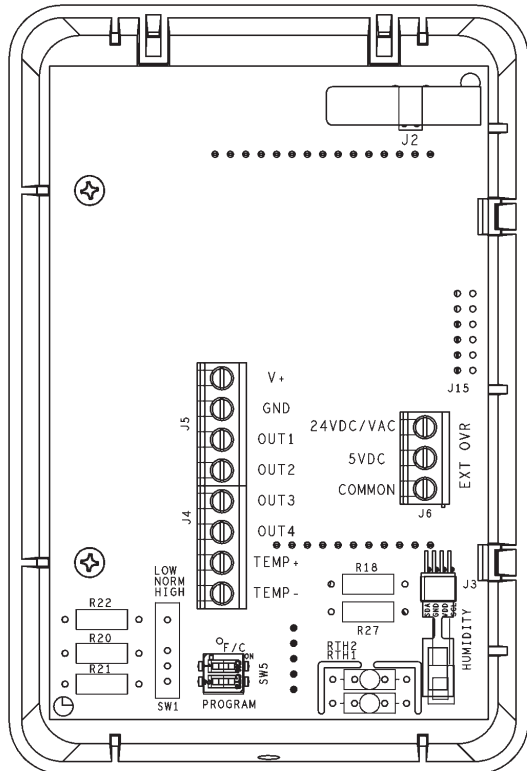

Fig. 5: BAPI-Stat “Quantum Prime” Circuit Board

Terminal Notes: (Related to Table 1)

V+: Power. See Power Supply specifications.

GND: Ground/Common for V+, OUT1, OUT2, OUT3, OUT4, and TEMP- terminals when configured as Common Ground (default)

OUT1: Temperature, Temperature Setpoint, or Humidity Setpoint with voltage or 4 to 20mA output.

OUT2: Humidity, Temperature Setpoint, or Humidity Setpoint with voltage or 4 to 20mA output.

OUT3/OUT4: Temperature Setpoint or Humidity Setpoint with voltage or resistive output. Resistive output can be wired as Differential Ground. Optional override available.

TEMP+/-: Resistive temperature sensor. Optional override available. Used as input for external sensor option (-ES). External sensor must be a 10K-2 thermistor purchased separately (max wire length of 25ft). A humidity output or resistive temperature sensor are not allowed in this configuration.

EXT OVR: Wiring of the J6 External Override (EXT OVR) terminals is not covered in this section. It is described in the “Override Display Icon Activation” section on page 4.

See product label for configuration and termination information.

Fig. 6: Example Product Label

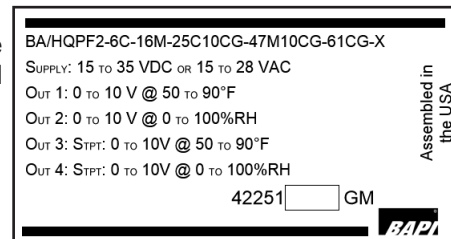

Table 1: Termination Table

Terminal Name	Output Variable					Output Type		
	Temp	Humidity	Temp Setpoint	Humidity Setpoint	Override	Voltage	Current	Resistive
OUT1	X		X	X		X	X	
OUT2		X	X	X		X	X	
OUT3			X	X	X	X		X (<50KΩ)
OUT4			X	X	X	X		X
TEMP+	X				X			X
TEMP-	X				X			X

Specifications subject to change without notice.

Front Panel & Control Descriptions

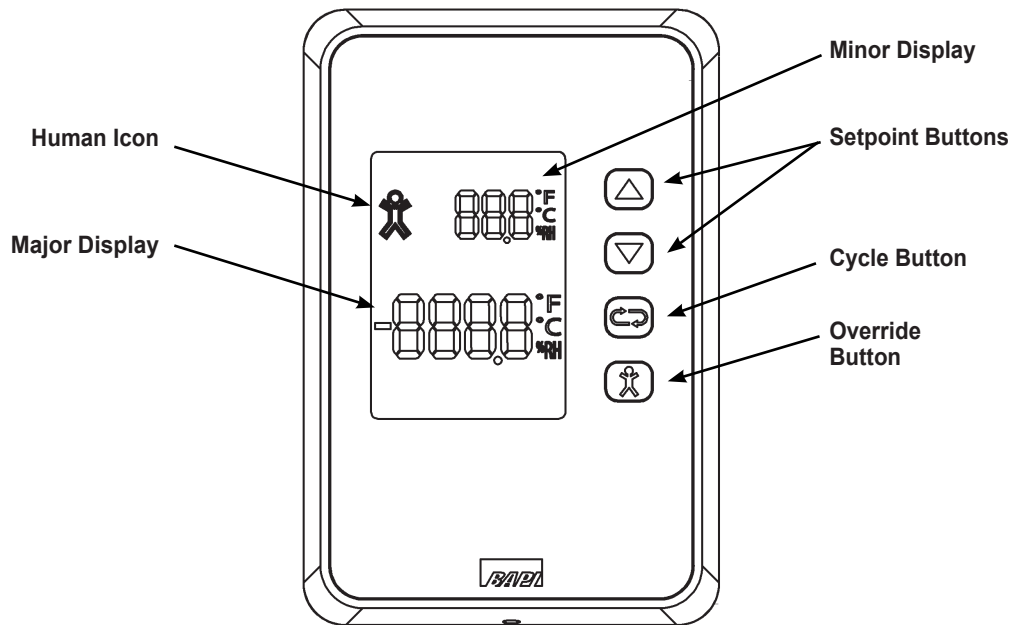

Fig. 7: BAPI-Stat “Quantum Prime” with Temperature and Humidity Setpoint and Override.

All BAPI-Stat “Quantum Prime” sensors come with a display. Depending on the options selected, the sensor will have one of three button configurations:

- No buttons;
- Setpoint & Override buttons (3 buttons);
- Setpoint, Cycle and Override (4 buttons) as shown in Figure 7.



Setpoint Buttons:



These buttons are used to change the setpoint. If your sensor has been ordered with setpoint adjustment for both temperature and humidity, then the setpoint value that changes is the one that is showing in the major display when the setpoint button is pressed. The major display digits will flash to indicate that the setpoint is being changed.



Cycle Button:

This button is used to switch the temperature and humidity values between the major and minor display.



Override Button:

This button sends a signal to the controller to place the sensor location into an occupied status. The Human Icon will appear in the display according to the wiring options described in the next section “Override Display Icon Activation.”

Temperature Display:

Temperature can be displayed in Fahrenheit or Celsius. It is field adjustable via the “F/C” switch on DIP Switch SW5 as described in the “Optional Technician Adjustments” section on page 5.



BAPI-Stat "Quantum Prime" Temp & Humidity Sensor

Installation & Operating Instructions

41148_ins_quantum_prime_hum

rev. 03/06/24

Human Icon Display Activation

When the override button is pushed, a resistance of less than 100 ohms appears for a few seconds across the OUT3, OUT4 or TEMP+/TEMP- terminals (depending on how the unit is ordered). Simultaneously, the outline and center of the Human Icon on the LCD will be lit for 10 seconds and then go blank.

If you would like the Human Icon to continue to display the "Occupied" or "Unoccupied" status of the room, then a confirmation signal of 5 VDC across the 5VDC and COMMON terminals of J6, or 24 VDC/VAC across the 24VDC/VAC and COMMON terminals of J6 is required. When the confirmation signal is received, both the outline and center of the Human Icon will be filled in or solid, indicating that the room is in an occupied state (Fig 8).

When the confirmation signal is removed, the center portion of the Human Icon will go out but the outline will remain lit, indicating that the room is in an unoccupied state. See the Wiring Examples below (Figs 9 & 10) for more info on adding the confirmation signal.

If power to the sensor is removed, the Human Icon will be blank until the first confirmation signal is received as described above.

Note: The input signals on the terminals of J6 are optically isolated from the rest of the device's circuitry.

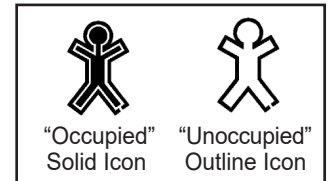
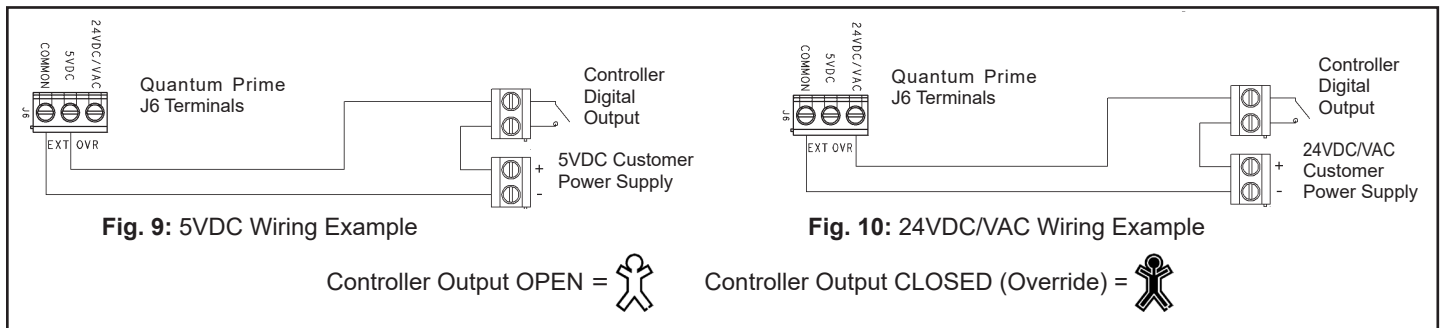

Fig. 8: Human Icon



Optional Communication Jack Termination Wiring

Fig. 11: C11 Jack

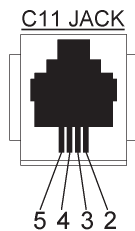

Table: 3 C11/22 Wiring	
Comm Jack Pin	Wire Color
1	Not Connected
2	Black
3	Red
4	Yellow
5	White or Green
6	Not Connected

Fig. 12: C35 Jack

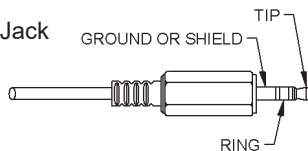

Table: 4 C35 Female Jack Wiring	
Comm Jack Pin	Wire Color
Ground	Black
Tip	White
Ring	Red

Note: Male Jack shown for clarity

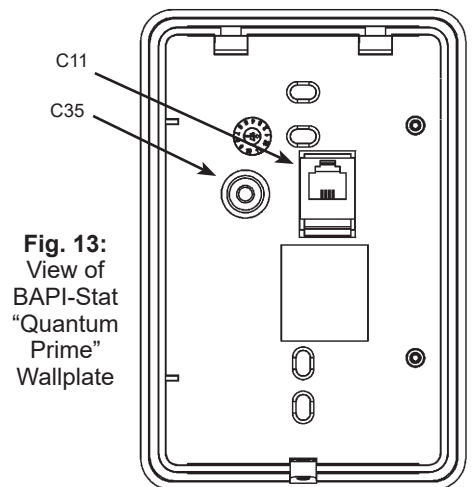

Fig. 13: View of BAPI-Stat "Quantum Prime" Wallplate

Optional Test & Balance Switch (SW1) - For Passive Sensor Output Only (Output at TEMP+ and TEMP- Terminals)

Optional Test and Balance Switch (SW1)

(Output at TEMP+ and TEMP- Terminals)

- High:** Will set the sensor value high
- Norm:** Thermistor/RTD will operate normally
- Low:** Will set the sensor value low

Sensor Type	Low Temp (40° F) Resistance Value	High Temp (105° F) Resistance Value
1000Ω RTD	1.02KΩ (41.20°F)	1.15KΩ (101.5°F)
3000Ω Thermistor	7.87KΩ (39.8°F)	1.5KΩ (106.8°F)
10K-2 Thermistor	30.1KΩ (34.9°F)	4.75Ω (109.1°F)
10K-3 Thermistor	26.7KΩ (35.9°F)	5.11KΩ (108.4°F)
10K-3(11K) Thermistor	7.32KΩ (43.7°F)	3.65Ω (105.2°F)

Specifications subject to change without notice.



BAPI-Stat “Quantum Prime” Temp & Humidity Sensor

Installation & Operating Instructions

41148_ins_quantum_prime_hum

rev. 03/06/24

Optional Technician Adjustments

The unit is shipped ready to install per the order. The following Setup or Program Menu Changes are available if the installer decides to change the factory settings. Note: the programming pages require setpoint and override buttons. The parameter adjustments are not available for units without buttons.

ENTERING PROGRAM MODE TO ADJUST PARAMETERS (see Figs 14-16 for adjustment tools)

1. Power unit and set DIP Switch SW5 #2 (PROGRAM) to ON (right). The LCD will show a page number (P1-P19). P1-P19 will flash to indicate that display parameter can be adjusted.
2. The Setpoint Up/Down buttons on the front of the unit are used to scroll up and down through pages and adjusting the page parameters.
3. The Override button acts as “Enter” to switch between page number and adjusting the page parameter.
4. After a page parameter has been adjusted, push the Override button to confirm the change.
5. To exit Program Mode, Set DIP Switch SW5 #2 (PROGRAM) to OFF (left).

Note: DIP Switch SW5 #1 (°F/°C) can be used to switch the display between °F and °C.

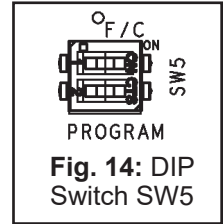

Fig. 14: DIP Switch SW5

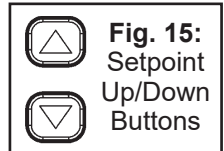

Fig. 15: Setpoint Up/Down Buttons

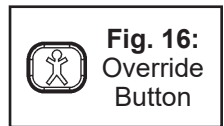

Fig. 16: Override Button

Programming Pages		
Parameter	Page	Adjustment
Temperature Offset	P1	±5° in 0.1° increments (If resistive temp output, offset only adjusts display. If voltage or current temp output, offset adjusts display & output.)
Humidity Offset	P2	±5% in 0.1% increments (Humidity offset adjusts the display and output.)
Setpoint Lockout	P3	Item Display Action
		0 Setpoint Enabled
		1 Setpoint Disabled: Display shows setpoint when activated, but can't be changed
		2 Setpoint Display: Shows setpoint in major display and shows opposite local temperature or humidity in minor display. Note: Temperature only unit or Humidity only unit will only show the setpoint in the major display.
		3 Setpoint Not Displayed: Setpoint can be changed, but will not display
Temperature Display	P4	Item Display Action
		0 Display in whole digits
		1 Display in 0.5° increments, °F and °C
		2 Display in 0.1° increments, °F and °C
Humidity Display	P5	Item Display Action
		0 Display in whole digits
		1 Display in 0.5% increments
		2 Display in 0.1% increments
Temperature Setpoint Display Low	P6	Adjust the Low Temperature of the setpoint range (Note: Minimum -40°F/-40°C)
Temperature Setpoint Display High	P7	Adjust the High Temperature of the setpoint range (Note: Maximum 185°F/85°C)
OUT3 Setpoint Output Low	P8	Low Setpoint Output Range (Note: Read Only. Displayed in 10 ohm resolution. Voltage outputs will be shown in ohms)
OUT3 Setpoint Output High	P9	High Setpoint Output Range (Note: Read Only. Displayed in 10 ohm resolution. Voltage outputs will be shown in ohms)
Temperature Setpoint Value	P10	Shows current temperature setpoint value (Note: Ready Only)
Humidity Setpoint Display Low	P11	Adjust the Low Humidity of the setpoint range (Note: Minimum 0%RH)
Humidity Setpoint Display High	P12	Adjust the High Humidity of the setpoint range (Note: Maximum 100%RH)
Humidity Setpoint Value	P13	Shows current humidity setpoint value (Note: Ready Only)
Temperature Output Low	P14	Adjust the Low Temperature of the output range (Note: Minimum -40°F/-40°C. Active temperature output only)
Temperature Output High	P15	Adjust the High Temperature of the output range (Note: Maximum 185°F/85°C. Active temperature output only)
Humidity Output Low	P16	Adjust the Low Humidity of the output range (Note: Minimum 0%RH)
Humidity Output High	P17	Adjust the High Humidity of the output range (Note: Maximum 100%RH)
OUT4 Setpoint Output Low	P18	Low Setpoint Output Range (Note: Read Only. Displayed in 10 ohm resolution or 1 ohm resolution depending on setpoint output. Voltage outputs will be shown in ohms)
OUT4 Setpoint Output High	P19	High Setpoint Output Range (Note: Read Only. Displayed in 10 ohm resolution or 1 ohm resolution depending on setpoint output. Voltage outputs will be shown in ohms)

Specifications subject to change without notice.



BAPI-Stat “Quantum Prime” Temp & Humidity Sensor

Installation & Operating Instructions

41148_ins_quantum_prime_hum

rev. 03/06/24

Diagnostics

POSSIBLE PROBLEMS

POSSIBLE SOLUTIONS:

General diagnostics

- Verify that the input is set up correctly in the controller’s and building automation software.
- Check for proper power at the sensor as described in the specifications below.
- Check wiring for proper termination and for corrosion at either the controller or the sensor. Clean off the corrosion, re-strip the interconnecting wire and reapply the connection. In extreme cases, replace the controller, interconnecting wire and/or sensor.
- Check for a wiring problem between the unit and the controller. Label the terminals at the sensor end and the controller end. Disconnect the interconnecting wires at both ends and measure the resistance from wire-to-wire with a multimeter. The meter should read greater than 10 Meg-ohms, open or OL depending on the meter you have. Short the interconnecting wires together at one end. Go to the other end and measure the resistance from wire-to-wire with a multimeter. The meter should read less than 10 ohms (22 gauge or larger, 250 feet or less). If either test fails, replace the wire.

Passive temperature sensor reading is incorrect at the controller

- Measure the physical temperature at the sensor’s location using an accurate temperature standard. Disconnect the temperature sensor wires at the TEMP+ and TEMP- terminals and measure the temperature sensor’s resistance across the terminals with an ohmmeter. Compare the temperature sensor’s resistance to the appropriate temperature sensor table on the BAPI website. If the measured resistance is different from the temperature table by more than 5% call BAPI technical support. Find BAPI’s website at www.bapihvac.com; click on “Resource Library” and “Sensor Specs” then click on the type of sensor you have. Don’t forget to reconnect the wires.
- If the unit has a Test and Balance switch, make sure it is in the correct position.

Specifications

Power Supply:

- 100 to 40 VDC (15 to 24 VDC Recommended) for 4 to 20 mA or 0 to 5 VDC Outputs
- 15 to 40 VDC (15 to 24 VDC Recommended) for 0 to 10 VDC Outputs
- 12 to 28 VAC (Requires a separate pair of shielded wires) for 0 to 5 VDC Outputs
- 15 to 28 VAC (Requires a separate pair of shielded wires) for 0 to 10VDC Outputs

Power Consumption:

- 100 mA maximum DC: 4 to 20 mA Output (<30mA typical)
- 75 mA maximum DC: 0 to 5 VDC or 0 to 10 VDC Outputs (6mA typical)
- 1.9 VA maximum AC: 0 to 5 VDC or 0 to 10 VDC Outputs (0.2VA typical)

Outputs: 4 active outputs plus 1 passive temperature sensor

- Volts..... 0 to 5 VDC or 0 to 10VDC, Impedance >10KΩ (OUT1, OUT2, OUT3, OUT4)
- Current..... 4 to 20 mA, Impedance <500Ω @ 24 VDC (OUT1, OUT2)
- Resistance Setpoint, 5 VDC @ 5 mA max (OUT3, OUT4) - Factory selected per application
- Relay Contact N.O., 500 mA @ 24 VDC max
- Temp. Sensor..... Passive RTD or Thermistor (TEMP+/TEMP-)

Inputs:

- External Override... 5 VDC or 24 VDC/VAC
- External Sensor 10K-2 Themistor purchased separately.
Wired 25’ max from sensor

Sensing Elements for Active Outputs and Display:

- Temperature..... 10K-2 Thermistor
- Humidity Capacitive Polymer, ±2%RH

Sensing Element for Resistive Temp Output: Thermistor or RTD

Mounting: Standard 2”x4” junction box, European junction box or drywall mount (screws provided)

Environmental Ambient:

- Temperature..... 32 to 122°F (0 to 50°C)
- Humidity 0 to 95%, non-condensing
- Storage 32 to 185°F (0 to 85°C)

Wiring: 2 to 6 pair of 16 to 22 AWG

Enclosure Material: ABS Plastic, UL 94, V-0

Agency: CE EN 61326-1:2013 EMC (Industrial Electromagnetic Environment), RoHS

Specifications subject to change without notice.