

Termination

BAPI recommends using twisted pair of at least 22AWG and sealant filled connectors for all wire connections. Larger gauge wire may be required for long runs. All wiring must comply with the National Electric Code (NEC) and local codes. Do NOT run this device's wiring in the same conduit as AC power wiring of NEC class 1 or NEC class 2, NEC class 3 or with wiring used to supply highly inductive loads such as motors, contactors and relays.

BAPI's tests show that fluctuating and inaccurate signal levels are possible when AC power wiring is present in the same conduit as the signal lines. If you are experiencing any of these difficulties, please contact your BAPI representative.



BAPI does not recommend wiring the sensor with power applied as accidental arcing may damage the product and will void the warranty

Mounting

Mount the unit to its mounting surface with two #8 screws through the holes in the mounting feet. The preferred mounting orientation is with the pressure ports facing down.

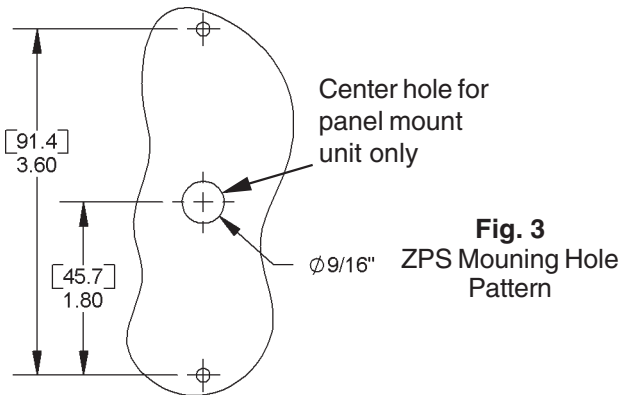

Fig. 3
ZPS Mounting Hole Pattern

1/16" (.06)	0"
3/16" (.19)	1/8" (.13)
5/16" (.31)	1/4" (.25)
7/16" (.44)	3/8" (.38)
9/16" (.56)	1/2" (.50)
11/16" (.69)	5/8" (.63)
13/16" (.81)	3/4" (.75)
15/16" (.94)	1"

White; to Analog input of Controller

Red; +24VDC/24VAC (Voltage out for AC)

Black; to Ground (voltage out) or Analog input of Controller (4 to 20 mA out)

White; to Analog input of Controller

Red; +24VDC/24VAC (Voltage out only for AC)

Black; To Ground (voltage out) or Analog input of controller (4 to 20 mA out)

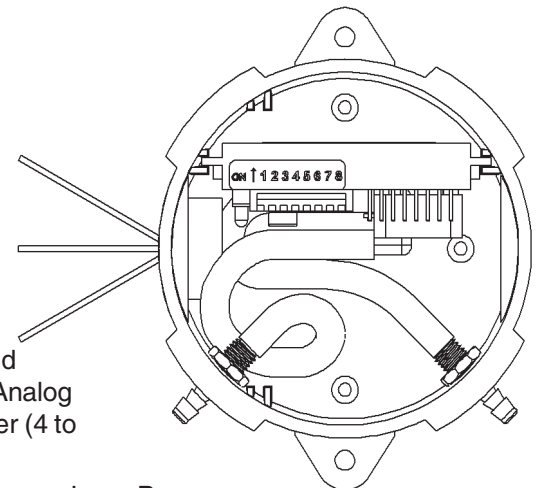

Low Pressure Port labeled "L"

High Pressure Port Labeled "H"

Fig. 1
BAPI ZPS Pressure Transmitter without Display

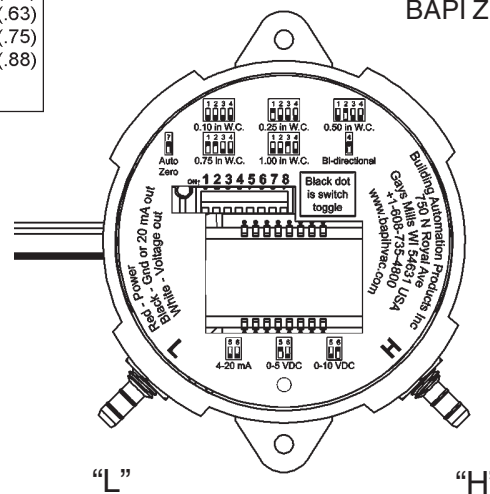

Note: Remove Blue Dust Shielded from pressure port before use.

Note: BAPI recommends using #8 screws that require 1/8" pilot holes

Fig. 2
BAPI ZPS Pressure transmitter with display

Tools & Material List

Screwdriver, #10 Screws, Drill with 5/32" Bit, Wire and Sealant Filled Connectors

Specifications subject to change without notice.

Output Termination

Desired Output	Wire connections
4 to 20 mA	Red (V+); Black (Return{4 to 20 mA Signal}); White (Not used)
0 to 5 V or 0 to 10 V	Red (V+); Black (Ground); White (Output Voltage)

4 to 20 mA is “two wire” operation, the ZPS’s red wire connects to a positive direct current voltage of 7 to 45 VDC, the ZPS’s black wire becomes the return of the 4 to 20 mA signal and the ZPS’s white wire, while unused, must be insulated from accidental contact with ground or any other potential. For 4 to 20 mA signaling only direct current can be used to power the ZPS.

0 to 5 V or 0 to 10 V is “three wire” operation, the ZPS’s red wire connects to either 7 to 45 VDC or 7 to 32 VAC (0-5 VDC output) or 13 to 45 VDC or 13 to 32 VAC (0-10 VDC output), the ZPS’s black wire is connected to ground and the ZPS’s white wire is connected to an analog input of the controller. BAPI insulates the white wire in the factory before shipping to you, please remove the connector and strip the insulation from the white wire as desired.

To ensure that all wires are properly terminated, twist the stripped ends of each circuit together before inserting into the splice terminals. Gently tug on the wire after terminating to make sure of a good connection. If the wire comes out of the termination repeat the splice procedure.

Pressure Range Select

To adjust the pressure range, set dip switches 1-4 to the desired pressure range using the the label found inside the twist off cover of the ZPS unit (or shown below on this page). Moving the Bi-Directional dip switch (#4) to the up position doubles the pressure range. For example, the 0 to .25” W.C. range becomes -.25” to .25” W.C. if the Bi-Directional dip switch is in the up position.

Note: If any of the switches are placed in an undefined combination the LED will fast blink and the output will be forced to 4mA or zero volts.

Output Range Select

To adjust the output range, set dip switches 5 & 6 to the desired output range using the the label found inside the twist off cover of the ZPS unit (or shown below on this page).

Note: If any of the switches are placed in an undefined combination the LED will fast blink and the output will be forced to 4mA or zero volts.

Dip Switch Settings - Inches & Pascals

NOTE: The black square is the switch position.

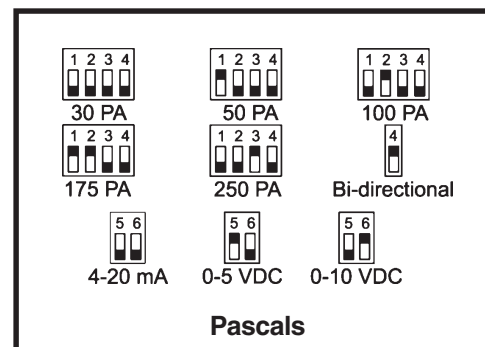
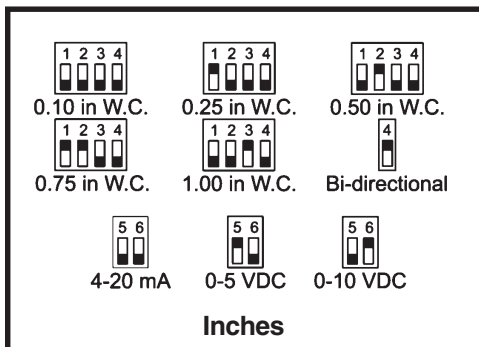

Switch 8

Switch 8 is reserved for Factory use, leave in the off position.

Specifications subject to change without notice.

Auto-Zero Select

To auto zero the BAPI ZPS, remove the tubing from the pressure ports (to remove the normal pressure source). Make sure that the pressure ports are sheltered from any drafts, including the technician's breath. Ideally the two ports should be connected together with a short piece of tubing. Turning on switch 7 starts the auto-zero process. Switches 1 through 6 may be in any allowed configuration. The LED will blink at a fast rate and the output will be forced to zero (4mA or 0V) while the auto-zero is being performed. When the LED blinks at a slow rate, turn off switch 7 and reconnect the pressure source.

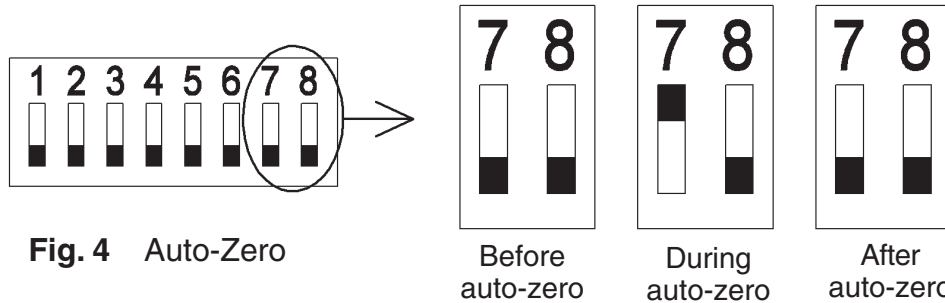

Fig. 4 Auto-Zero

Typical Applications

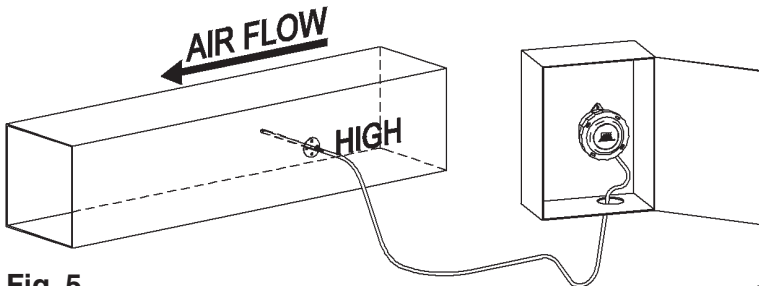

Fig. 5
Duct static pressure monitoring, BAPI ZPS Pressure Transmitter mounted in a panel with ZPS-ACC07 in duct..

NOTE: Best practice is to form a drip loop in the tubing preventing condensation from reaching the ZPS.

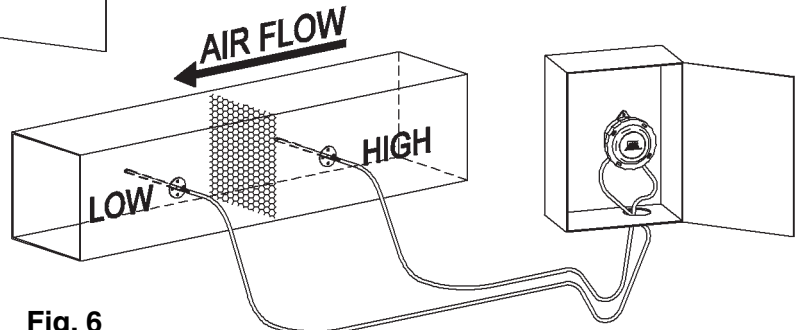

Fig. 6
Air filter pressure drop monitoring, ZPS Pressure Transmitter mounted in a panel with two ZPS-ACC07 in duct.

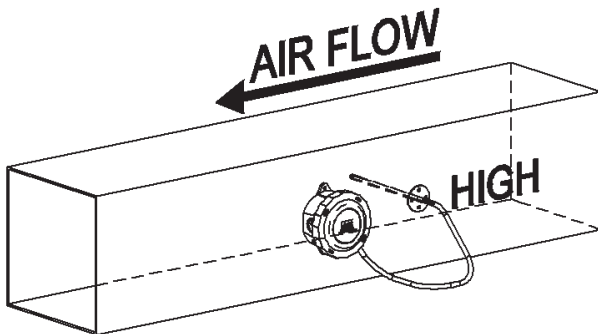

Fig. 7
Duct static pressure monitoring, BAPI ZPS Pressure Transmitter mounted on the duct with ZPS-ACC07 in duct.

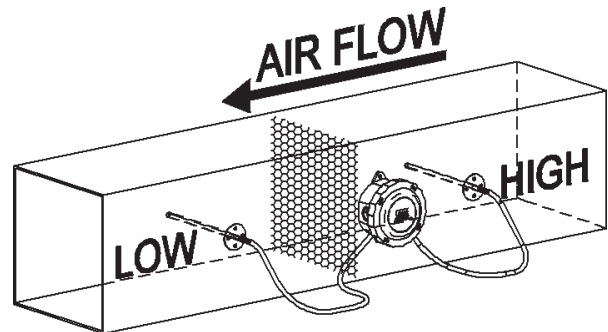

Fig. 8
Air filter pressure drop monitoring, BAPI ZPS Pressure Transmitter mounted on the duct with two ZPS-ACC07 in duct.

Specifications subject to change without notice.

Troubleshooting

Problems:

LED does not light

LED is blinking fast
1/2 second on 1/2 second off

Output stuck (high or low)

Output not tracking pressure properly

Possible Solutions:

- Check power connections for proper power

- The unit may be performing an auto-zero. Wait 10 seconds and check again.
- The dip switches are in an unsupported configuration, check the dip switch settings, both pressure and output, and change them to ranges desired

- Remove pressure from ports and perform auto-zero procedure

- Check dip switches for proper pressure range selection
- Check dip switches for proper output range selection

LED Operation

LED off	No Power
LED Blinking 1/4 sec on, 1/4 sec off	Auto-zero or dip switch in undefined configuration
LED on	Normal operation
LED Blinking 1/2 sec on, 4 sec off	Auto-zero complete

Specifications subject to change without notice.