

### Overview

Today's high cost of energy mandates proportional control, you only use the exact amount of energy necessary to get the job done. Modern actuator technology makes proportional control easy for water valves and air dampers, but proportional control for electric heat, fans and refrigeration systems may be complex and cost prohibitive.

The BAPI BA/SQ4RA sequences multiple on-off devices based on a single analog output from any controller. Now items such as cooling towers with multiple two-speed fans, staged electric heat and multi-compressor chillers can be cost effectively controlled to provide the utmost efficiency and consistency for the load at hand. Each BA/SQ4RA provides four NO/NC outputs that open and close at fixed voltages across the control voltage range. Two BA/SQ4RA devices may be cascaded to provide eight output stages. Each output on the BA/SQ4RA can be set for normal or inverted polarity and provides 24VDC at 80mA.

The BA/SQ4RA is capable of rotating its output sequences. Rotating output sequences can save wear and tear on equipment as well as save energy. Simply setting the controllers voltage to the device to less than 0.5 VDC changes the sequence.

The BA/SQ4RA has four dry contacts inputs and an alarm output. Approximately two seconds after an output changes state the device senses the condition of the dry contact inputs (usually from contactor side contacts). If the open/close states of the four dry contact inputs do not match the output request, the alarm contacts will close.

All outputs open when power is removed from the device.

### Mounting

The BA/SQ4RA plugs into either a BA/BP4 or BA/BP8 as shown in Figure 1.

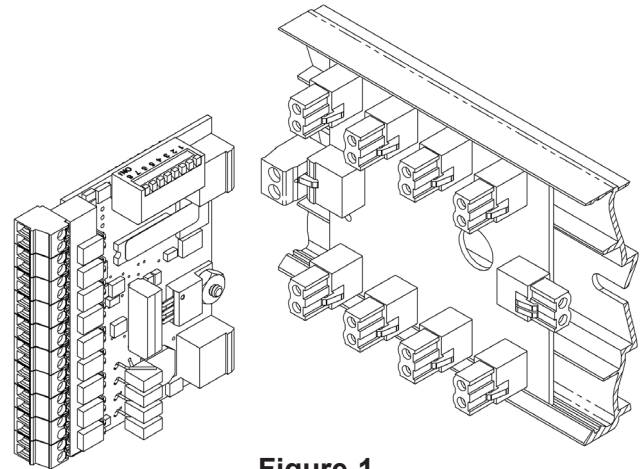

**Figure 1**  
BA/SQ4RA plugging into a BA/BP4

### Termination

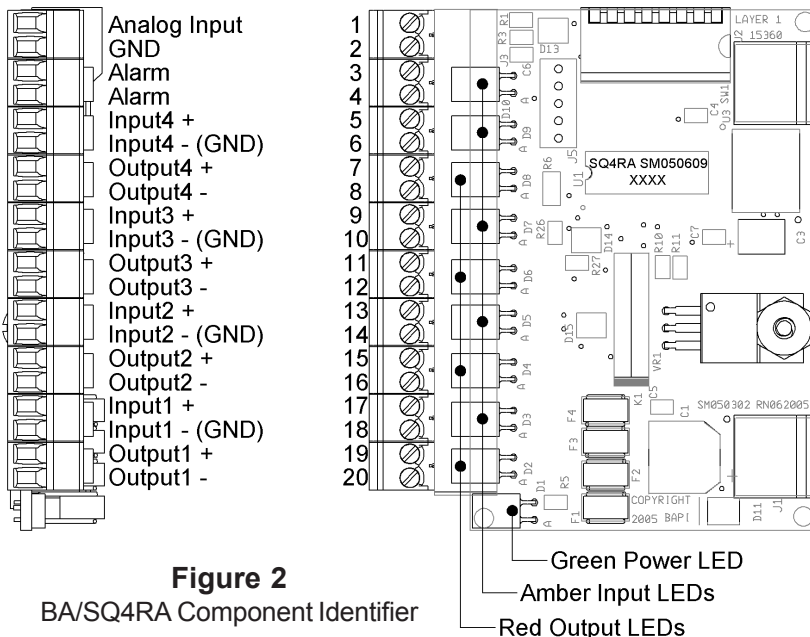

**Figure 2**  
BA/SQ4RA Component Identifier

Table 1: BA/SQ4RA Connection List	
Terminal	Function
Pin 1	Analog voltage from Controller +
Pin 2	Analog voltage from Controller -
Pin 3	Alarm Output (Dry Contact +)
Pin 4	Alarm Output (Dry Contact -)
Pin 5	Input 4 + (5.6KΩ pull-up to 34VDC)
Pin 6	Input 4 -
Pin 7	Output 4 + (24VDC @ 80mA)
Pin 8	Output 4 -
Pin 9	Input 3 + (5.6KΩ pull-up to 34VDC)
Pin 10	Input 3 -
Pin 11	Output 3 + (24VDC @ 80mA)
Pin 12	Output 3 -
Pin 13	Input 2 + (5.6KΩ pull-up to 34VDC)
Pin 14	Input 2 -
Pin 15	Output 2 + (24VDC @ 80mA)
Pin 16	Output 2 -
Pin 17	Input 1 + (5.6KΩ pull-up to 34VDC)
Pin 18	Input 1 -
Pin 19	Output 1 + (24VDC @ 80mA)
Pin 20	Output 1 -

Note: The male connectors that plug into the jacks on the board use a rising block screw terminal to hold the wires. If the block is in a partially up position the wire may be inserted under the block and the wire will not be held when the screw is tightened. To avoid improper wiring, turn the male connector screws counterclockwise until the block is below the wire opening before inserting the wire. Lightly tug on each wire after tightening to verify proper termination.

Specifications subject to change without notice.

## Operation

The switch settings that govern how the BSQ4RA operate are listed in table 2. (The switch is OFF when the toggle is up and ON when the toggle is down.)

Setting switches 5, 6 and 7 of the BA/SQ4RA selects how many outputs you want to sequence. Up to eight outputs may be sequenced by using two BA/SQ4RA's in tandem. Table 3 at right shows how to set the switches for the desired number of outputs:

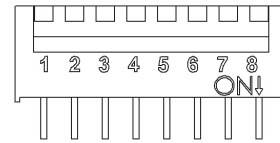

**Figure 3**  
Dip Switch showing switch numbers

**Table 2: BA/SQ4RA Switch Settings**

Switch	OFF Function (Default)[Switch Toggle Up]	ON function [Switch Toggle Down]
1	Output 1 Polarity normal	Output 1 Polarity inverted
2	Output 2 Polarity normal	Output 2 Polarity inverted
3	Output 3 Polarity normal	Output 3 Polarity inverted
4	Output 4 Polarity normal	Output 4 Polarity inverted
5	Selection Bit 0	Selection Bit 0
6	Selection Bit 1	Selection Bit 1
7	Selection Bit 2	Selection Bit 2
8	Analog voltage from controller = 0 to 10 VDC	Analog voltage from controller = 0 to 5 VDC

**Table 3: BA/SQ4RA Output Switch Settings**

# Of Outputs to Sequence	Switch 5	Switch 6	Switch 7
1	Off	Off	Off
2	On	Off	Off
3	Off	On	Off
4	On	On	Off
5	Off	Off	On
6	On	Off	On
7	Off	On	On
8	On	On	On

*Note: If sequencing less than the total number of outputs, the switching voltage remains the same as shown in the figures below.*

### FOUR OUTPUTS

If you plan to sequence 4 or less outputs, set switches 5 through 7 to the number you need as shown in Table 3. You have the option of using a 0-5 or a 0-10 volt controller voltage to sequence the outputs. Switch 8 sets the voltage.

The BA/SQ4RA takes an analog input voltage and turns on the desired relay driver outputs. The BA/SQ4RA allows the user to rotate the sequence of the outputs by setting the controllers voltage below 0.5 VDC. When the BSQ4 encounters 0.5 VDC or less from the controller, it will rotate the sequence automatically.

For example, with increasing controller voltage to the BA/SQ4RA, the BA/SQ4RA will initially drive output 1, then output 2, then output 3, then output 4. When the controller's voltage drops under 0.5 VDC, The BA/SQ4RA drives it's outputs beginning with output 2, then output 3, then output 4, then output 1. The next time the controller's voltage drops under 0.5 VDC, the BA/SQ4RA will drive output 3, output 4, output 1, then output 2. The sequencing advances as follows:

*Initial sequence: 1,2,3,4 • 1<sup>st</sup> 0 VDC Occurrence: 2,3,4,1 • 2<sup>nd</sup> 0 VDC Occurrence: 3,4,1,2  
3<sup>rd</sup> 0 VDC Occurrence: 4,1,2,3 • 4<sup>th</sup> 0 VDC Occurrence: 1,2,3,4 • 5<sup>th</sup> 0 VDC Occurrence: 2,3,4,1*

Every time the controller's voltage drops to 0VDC, the output sequence will change. See Figure 4 below. (Switch 8 ON)

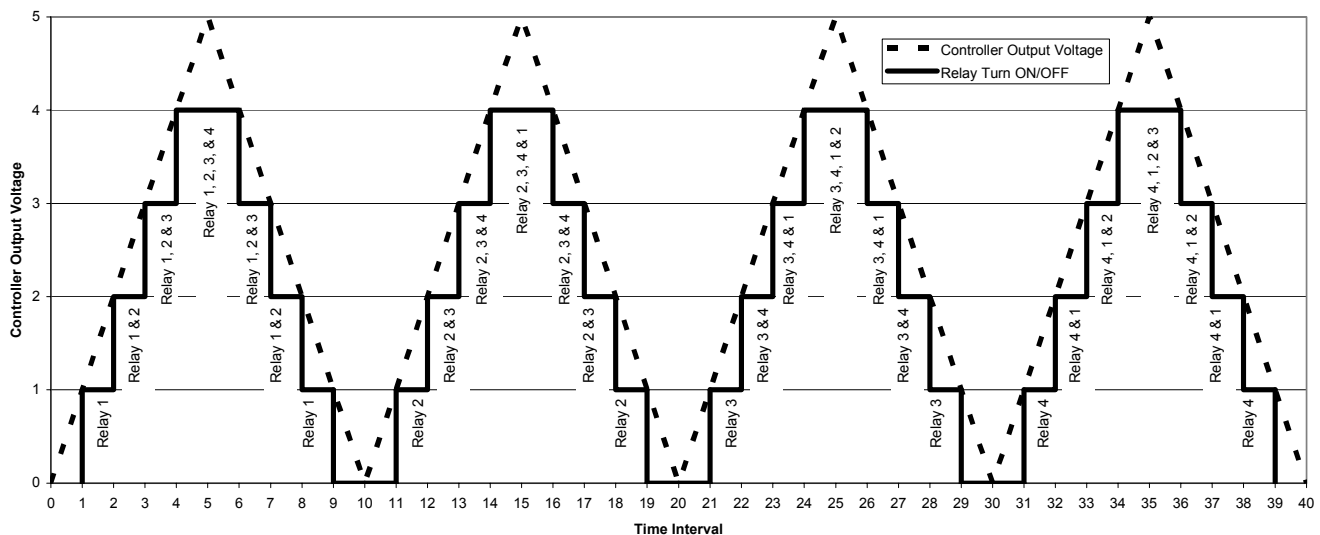

**Figure 4:** Rotational Sequence Four Outputs

The sequence will not change if the controller's voltage drops low enough that all relays turn off but does not drop below 0.5 VDC. See Figure 5 below. (Switch 8 OFF)

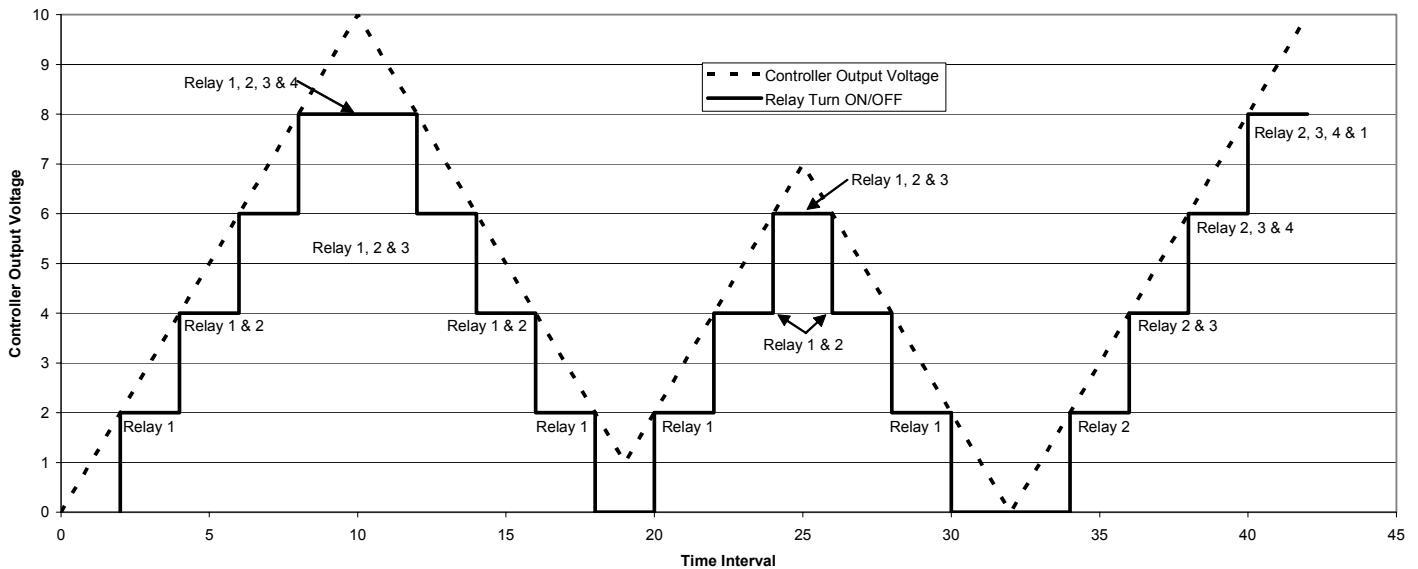
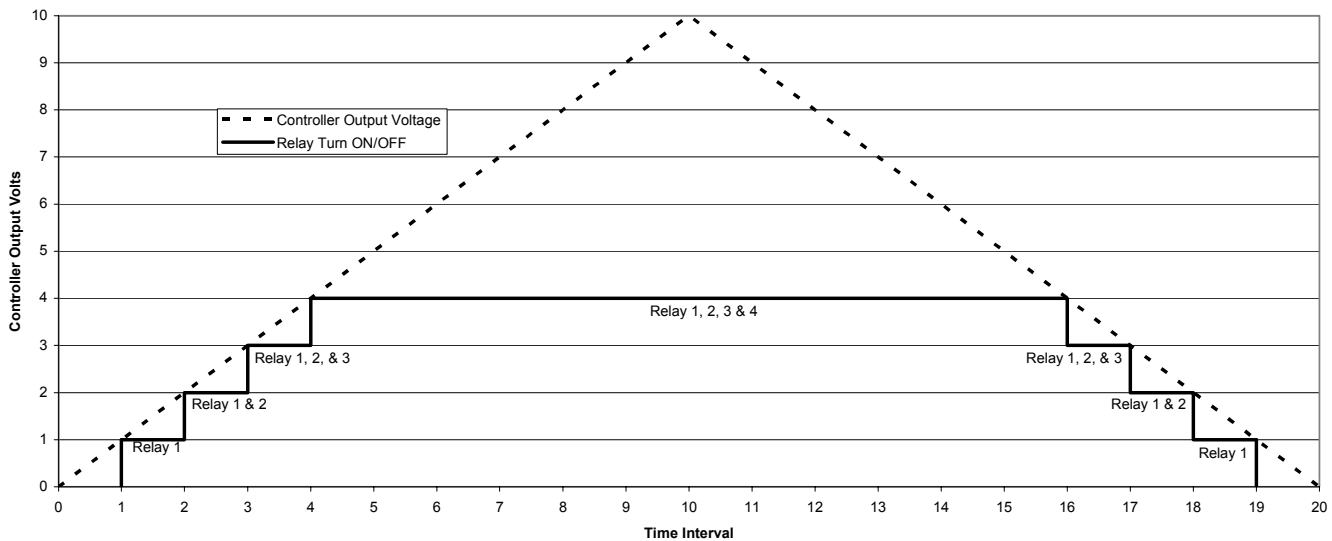

**Fig. 5:** Output sequence showing that the sequence does not rotate until controller voltage drops below 0.5VDC

Note: All step voltages have about 0.200 Volts of hysteresis. This means that once the outputs turn on, they'll have to drop by 0.200 volts before the outputs turn off. For example, if a given output turns on at 2.0 volts, it will turn off at 1.80 Volts. All voltages are +/- 5%.

### EIGHT OUTPUTS (Two SQ4RA Cards Connected Together)

BAPI realizes the need for flexibility and accuracy. Two BA/SQ4RA sequencer cards can be connected together to sequence up to 8 outputs. Connect the same controller voltage to the Analog In on both cards. Set switches 5, 6 and 7 ON, on both cards. (Sequencing 8 outputs) Designate one card as Board\_1 and the second as Board\_2. Set Board\_1 switch 8 OFF, the output sequence is illustrated in Figure 6:

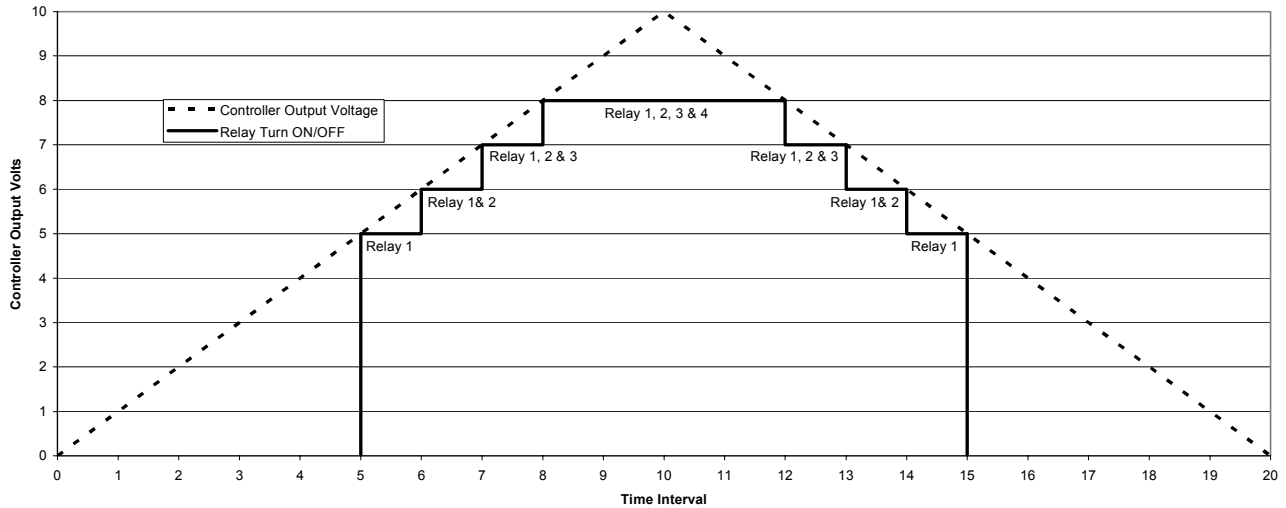

**Fig. 6:** Board\_1 output sequence

Specifications subject to change without notice.

**EIGHT OUTPUTS (Two SQ4RA Cards Connected Together) continued....**

Set Board\_2 switch 8 ON, the output sequence is illustrated in Figure 7:

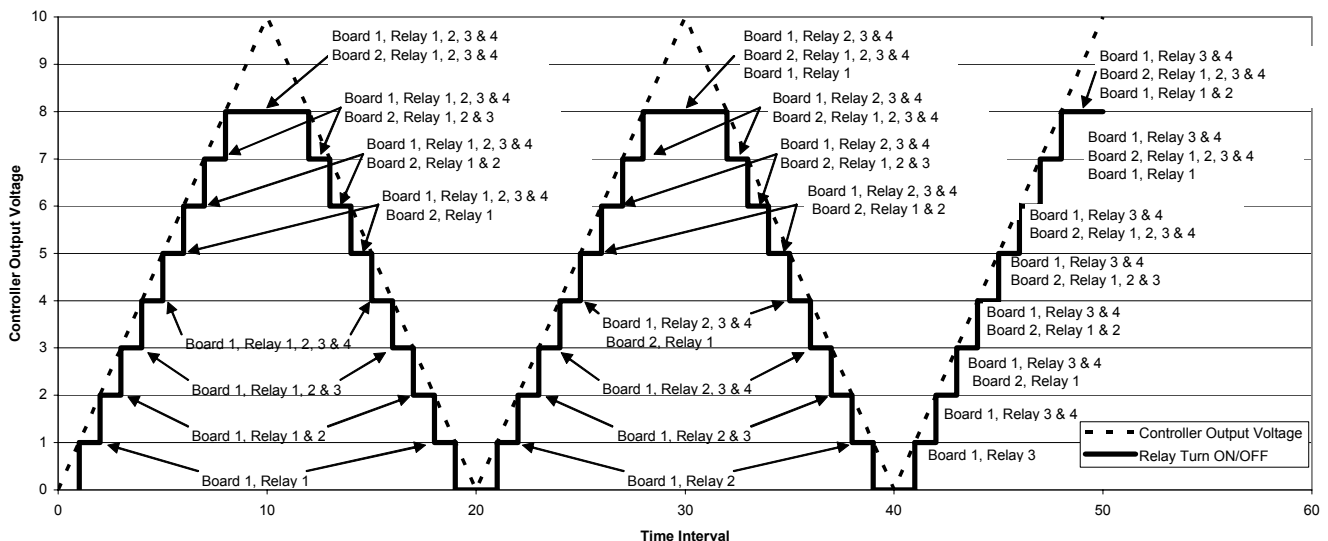

**Fig. 7:** Board\_2 output sequence

Figures 6 and 7 show the base sequence of two boards set up for 8 outputs, in conjunction with one another they provide eight discrete outputs over a 0-10 VDC control range. All eight outputs rotate their output sequence as shown in the following example, and is graphically shown in figure 8.

- Initial sequence: 1,2,3,4,5,6,7,8 • 1<sup>st</sup> 0 V Input Occurrence: 2,3,4,5,6,7,8,1
- 2<sup>nd</sup> 0V Input Occurrence: 3,4,5,6,7,8,1,2 • 3<sup>rd</sup> 0 V Input Occurrence: 4,5,6,7,8,1,2,3
- 4<sup>th</sup> 0 V Input Occurrence: 5,6,7,8,1,2,3,4 • 5<sup>th</sup> 0 V Input Occurrence: 6,7,8,1,2,3,4,5
- 6<sup>th</sup> 0 V Input Occurrence: 7,8,1,2,3,4,5,6 • 7<sup>th</sup> 0V Input Occurrence: 8,1,2,3,4,5,6,7
- 8<sup>th</sup> 0 V Input Occurrence: 1,2,3,4,5,6,7,8 • 9<sup>th</sup> 0 V Input Occurrence: 2,3,4,5,6,7,8,1

**NOTE:** Output 1,2,3,4 resides on Board\_1. Outputs 5,6,7,8 reside on Board\_2



**Fig. 8:** First three sequences in an eight-output configuration

**Specifications**

- Power Voltage ..... 26 to 36 VDC (from BAPI BA/PS17)
- Power Current ..... 50mA maximum plus output (1.7VA max plus output)
- Input Control Voltage ..... 0 to 5 VDC -OR- 0 to 10 VDC
- Alarm Output ..... 50mA max, non-inductive NEC Class 2
- Dry Contact Inputs ..... 5Ω max
- Output Power Voltage ..... nominal 24 VDC (23 to 32VDC)
- Output Power Current ..... 4 outputs of 80mAmp maximum (10 Watts total)