

Overview

Today's high cost of energy mandates proportional control, you only use the exact amount of energy necessary to get the job done. Modern actuator technology makes proportional control easy for water valves and air dampers, but proportional control for electric heat, fans and refrigeration systems may be complex and cost prohibitive.

The BAPI BA/SQ4A sequences multiple on-off devices based on a single analog output from any controller. Now items such as cooling towers with multiple two-speed fans, staged electric heat and multi-compressor chillers can be cost effectively controlled to provide the utmost efficiency and consistency for the load at hand.

Each BA/SQ4A provides four NO/NC dry contact outputs that open and close at fixed voltages across the control voltage range. Two BA/SQ4A devices may be cascaded to provide eight output stages. Each output, when closed, provides 24VDC at 80mA. All outputs open when power is removed from the device.

The BA/SQ4A has four dry contacts inputs and an alarm output. Approximately two seconds after an output changes state the device senses the condition of the dry contact inputs (usually from contactor side contacts). If the open/close states of the four dry contact inputs do not match the output request, the alarm contacts will close.

Mounting

The BA/SQ4A plugs into either a BA/BP4 or BA/BP8 as shown in Figure 1.

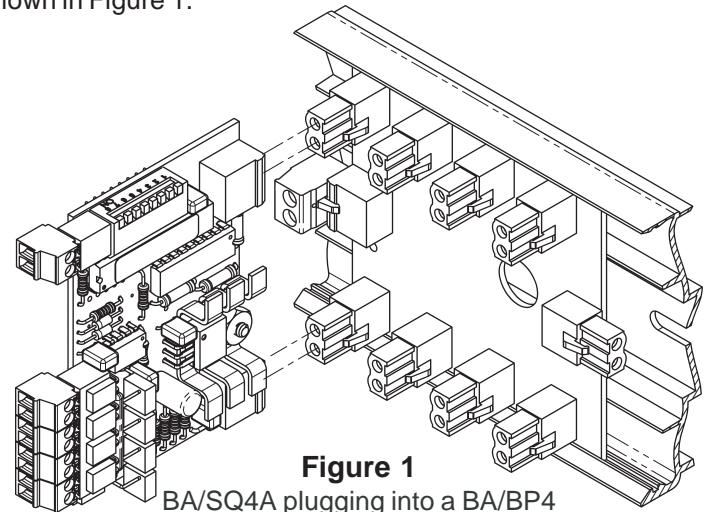

Figure 1
BA/SQ4A plugging into a BA/BP4

Termination

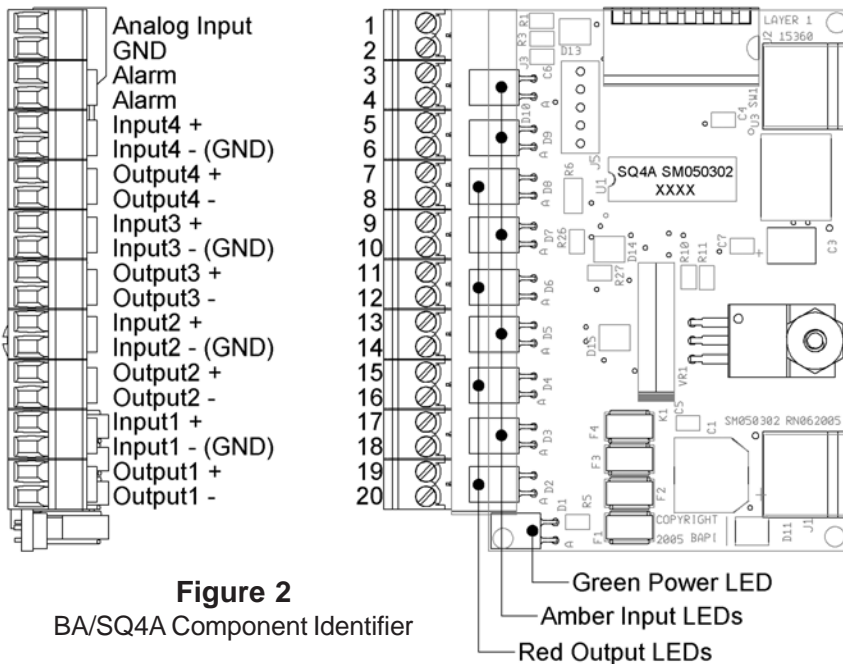

Figure 2
BA/SQ4A Component Identifier

Table 1: BA/SQ4A Connection List	
Terminal	Function
Pin 1	Analog voltage from Controller +
Pin 2	Analog voltage from Controller -
Pin 3	Alarm Output (Dry Contact +)
Pin 4	Alarm Output (Dry Contact -)
Pin 5	Input 4 + (5.6KΩ pull-up to 34VDC)
Pin 6	Input 4 -
Pin 7	Output 4 + (24VDC @ 80mA)
Pin 8	Output 4 -
Pin 9	Input 3 + (5.6KΩ pull-up to 34VDC)
Pin 10	Input 3 -
Pin 11	Output 3 + (24VDC @ 80mA)
Pin 12	Output 3 -
Pin 13	Input 2 + (5.6KΩ pull-up to 34VDC)
Pin 14	Input 2 -
Pin 15	Output 2 + (24VDC @ 80mA)
Pin 16	Output 2 -
Pin 17	Input 1 + (5.6KΩ pull-up to 34VDC)
Pin 18	Input 1 -
Pin 19	Output 1 + (24VDC @ 80mA)
Pin 20	Output 1 -

Note: The male connectors that plug into the jacks on the board use a rising block screw terminal to hold the wires. If the block is in a partially up position the wire may be inserted under the block and the wire will not be held when the screw is tightened. To avoid improper wiring, turn the male connector screws counterclockwise until the block is below the wire opening before inserting the wire. Lightly tug on each wire after tightening to verify proper termination.

Specifications subject to change without notice.

Operation

The switch settings that govern how the BA/SQ4A operate are listed in table 2. (The switch is OFF when the toggle is up and ON when the toggle is down.)

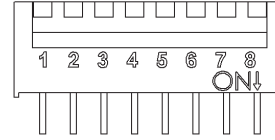

Figure 3
Dip Switch
showing switch
numbers

Table 2: BA/SQ4A Switch Settings

Switch	OFF Function (Default) [Switch Toggle UP]	On Function [Switch Toggle Down]
1	Output 1 Polarity Normal	Output 1 Polarity Inverted
2	Output 2 Polarity Normal	Output 2 Polarity Inverted
3	Output 3 Polarity Normal	Output 3 Polarity Inverted
4	Output 4 Polarity Normal	Output 4 Polarity Inverted
5	Alarm Output Polarity Normal	Alarm Output Polarity Inverted
6	0 Volt Offset	5 Volt Offset
7	0-10 Volts In	0-5 Volts In
8	Bar Mode	Dot Mode

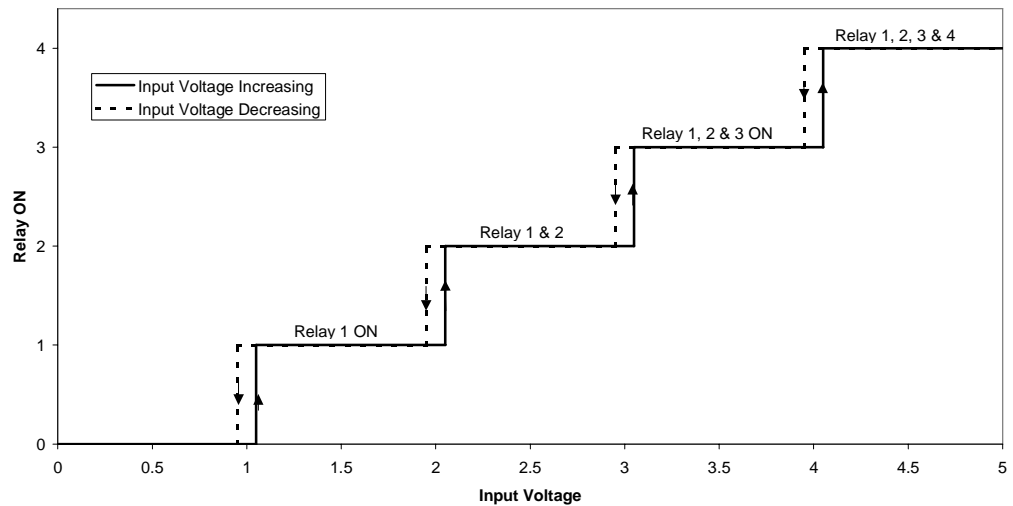

Figure 4: BA/SQ4A, 0-5 VDC input, 0 VDC offset, all outputs NO & Bar mode

Specifications subject to change without notice.

Figure 5: BA/SQ4A, 0-5 VDC input, 0 VDC offset, all outputs NO & Dot mode

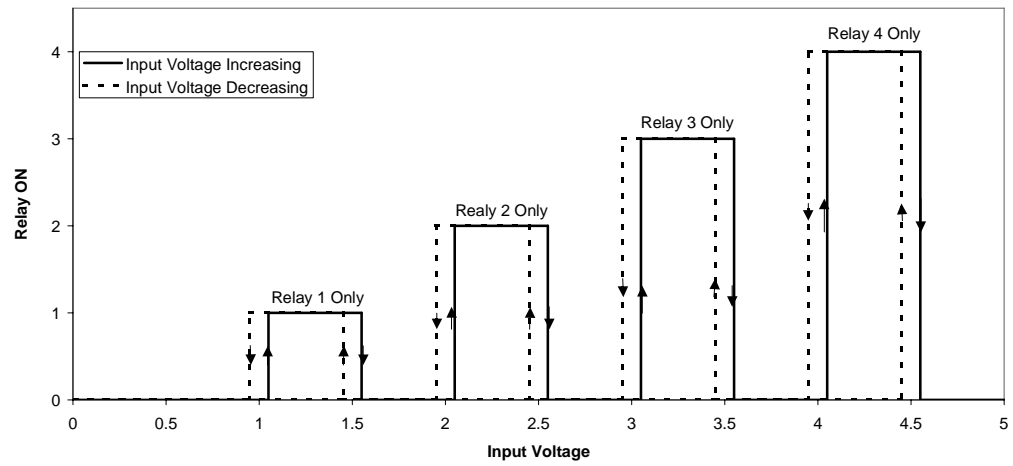

Figure 6; BA/SQ4A, 0-5 VDC input, 5 VDC offset & Bar or Dot mode

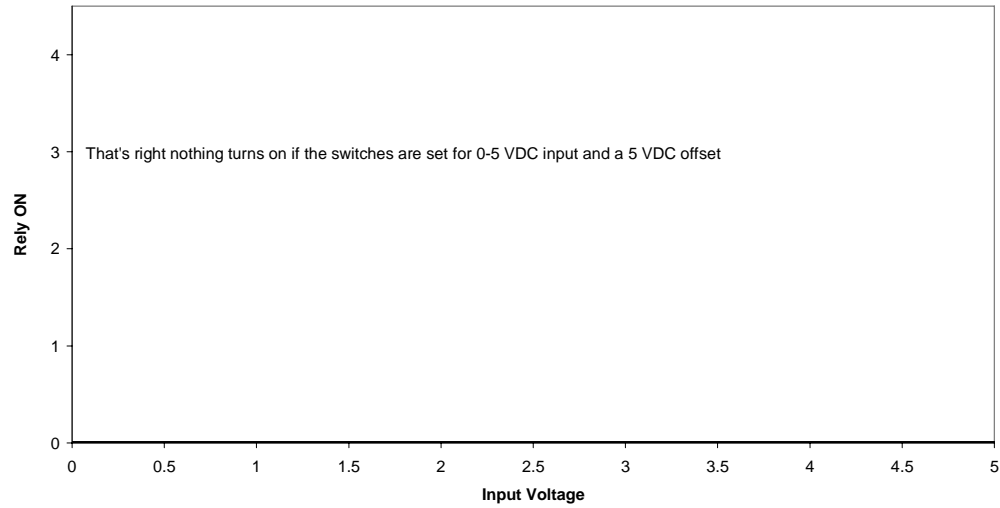
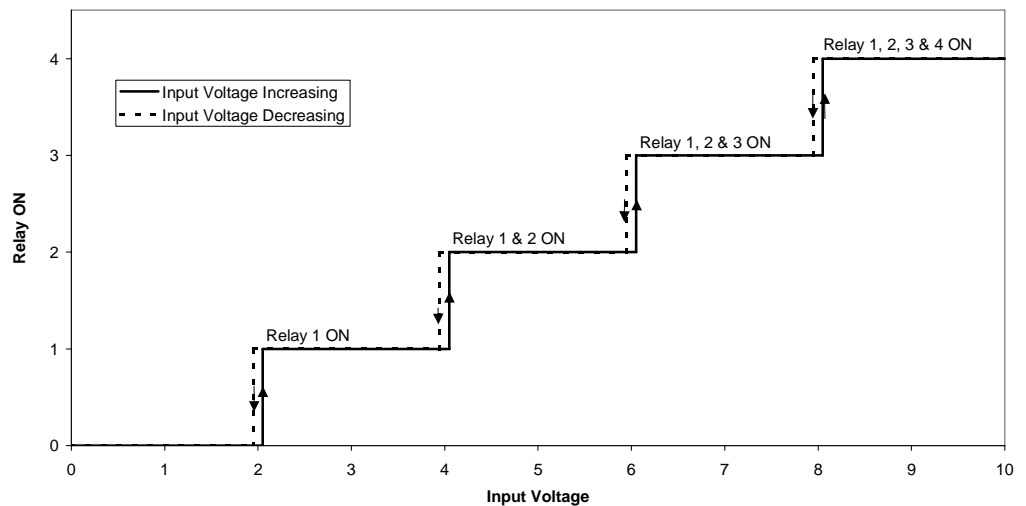

Figure 7: BA/SQ4A, 0-10 VDC input, 0 VDC offset, all outputs NO & Bar mode



Specifications subject to change without notice.

Figure 8: BA/SQ4A, 0-10 VDC input, 0 VDC offset, all outputs NO & Dot mode

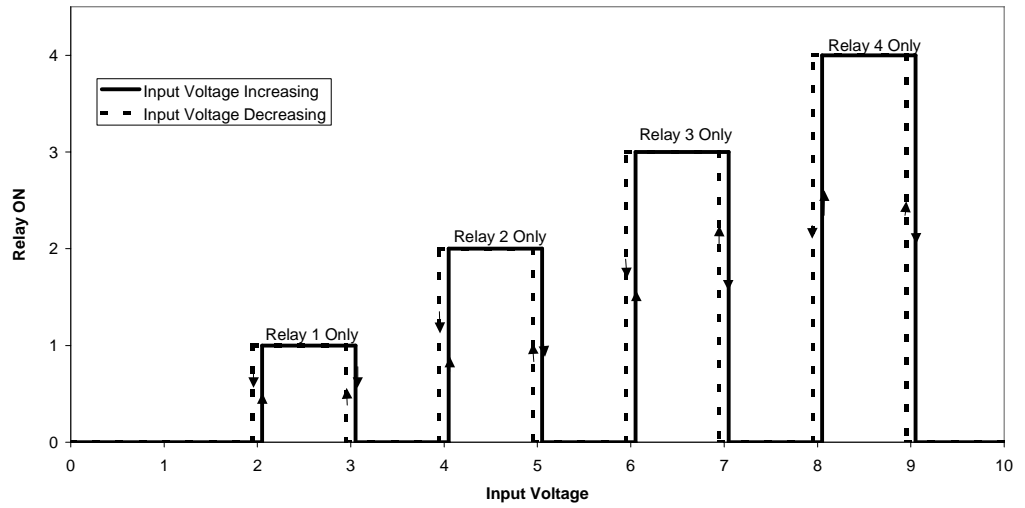

Figure 9: BA/SQ4A, 0-10 VDC input, 5 VDC offset, all outputs NO & Bar mode

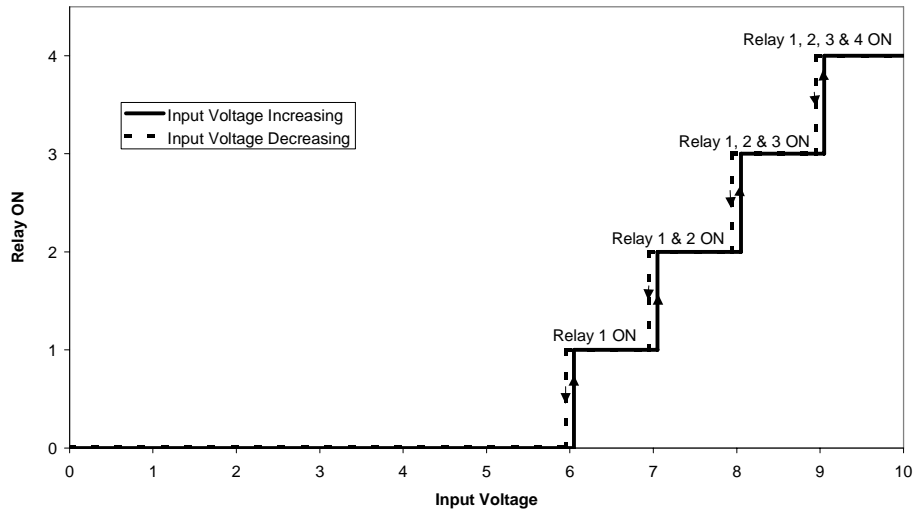
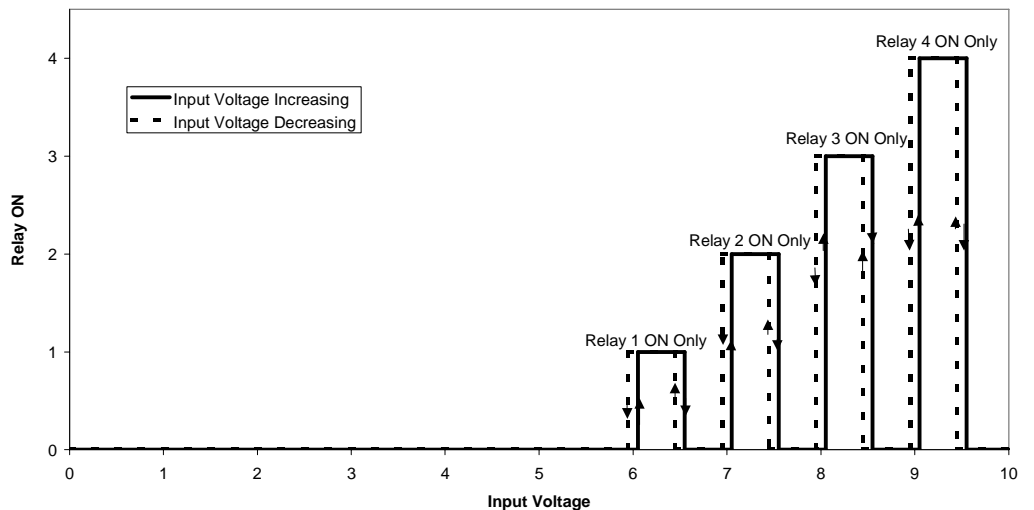

Figure 10: BA/SQ4, 0-10 VDC input, 5 VDC offset, all outputs NO & Dot mode



Specifications subject to change without notice.

EIGHT OUTPUTS

BAPI recognizes the need for very precise control. Two BA/SQ4A devices connected together proportionally energize eight outputs over a 0-10 VDC control voltage input range.

Refer to the two boards as Board_1 and Board_2. Board_1 is configured for 0-5 VDC input and 0 VDC offset. Board_2 is configured for 0-10 VDC input and 5 VDC offset. Connect the 0-10 VDC control voltage to both board's analog input terminals, J4 (See Figure 2). The two following sequence of operation diagrams show how the outputs change for a changing input voltage in Bar and Dot modes.

Figure 11: Two-BA/SQ4As connected together for eight outputs in Bar mode

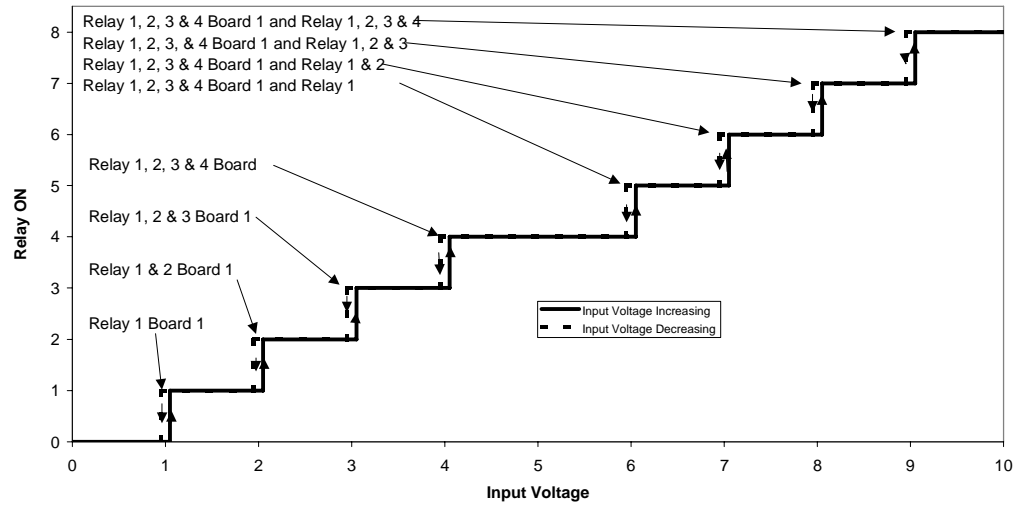
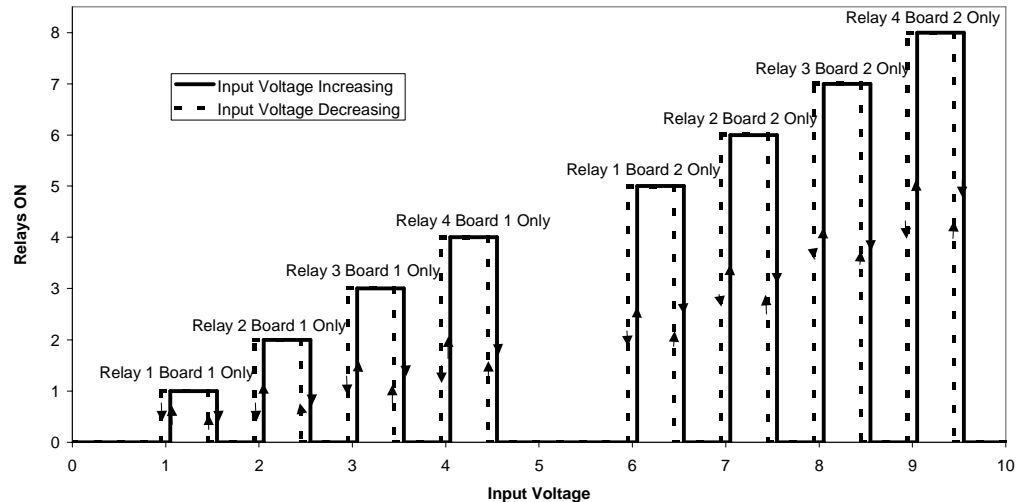

Figure 12: Two-BA/SQ4As connected together for eight outputs in Dot mode



Specifications subject to change without notice.



Troubleshooting

Possible Problems:

Power LED L1 does not light

Possible Solutions:

- Check to see that the BA/SQ4A is firmly inserted into the backplane
- Check to see if the power cable is firmly inserted into the backplane.
- Check to see if the PS17 is working correctly
- Check to see if the power to the PS17 is turned on

Relay drive LEDs L2 through L5 do not light

- Check output setting to see if drive LED should be on.
- Disconnect segment of J3 that does not light, if LED turns on check wiring or load for short to ground

Specifications

- Power Voltage 26 to 36 VDC (from BAPI BA/PS17)
- Power Current 50mA maximum plus output (1.7VA max plus output)
- Input Control Voltage 0 to 5 VDC -OR- 0 to 10 VDC
- Alarm Output 50mA max, non-inductive NEC Class 2
- Dry Contact Inputs 5Ω max
- Output Power Voltage nominal 24 VDC (23 to 32VDC)
- Output Power Current 4 outputs of 80mA maximum (10 Watts total)

Specifications subject to change without notice.